

SPECIFICATIONS

Rated thermal input	13 kW
Rated thermal input into water	6,5 kW
Efficiency	85 %
Smoke flue diameter	150 mm
Min. thrust (under pressure) for rated thermal input	11 Pa
Fuel gas temperature	190 °C
Volume of fuel gas	11,8 g/s
CO emissions in fuel gas (at 13 % O ₂)	0,0383 %
Dust in the fuel gas (at 13 % O ₂)	19 mg/Nm ³
Volume of fuel per hour	3,69 kg/h
Fuel	wood (beech logs)
Weight	338 kg



LIST OF SPARE PARTS

Heat exchanger connection diagram

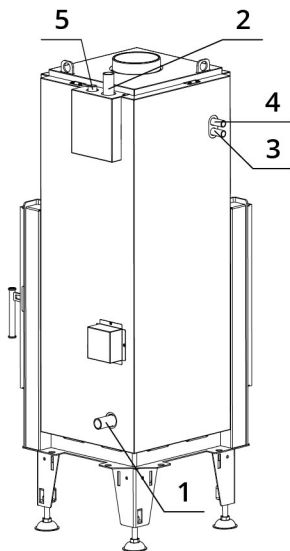

1. Cold water inlet to the heat exchanger (return), external thread 1"
2. Hot water outlet from the heat exchanger (riser), external thread 1"
3. Cold water inlet to thermal protection, external thread 1/2"
4. Heated water outlet from thermal protection, external thread 1/2"
5. Inlet for venting valve, internal thread 1/2"

Carcon stones

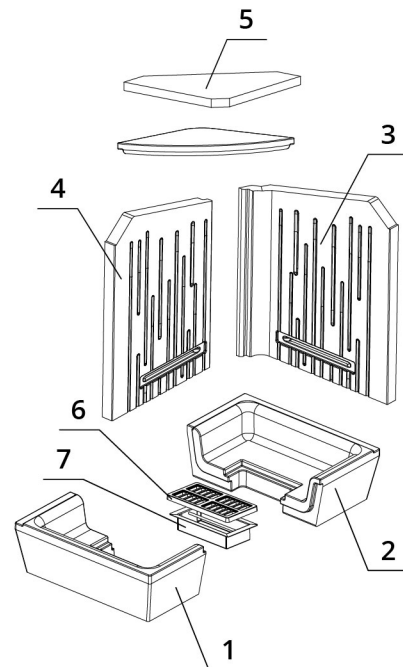

- | | | |
|-----------------|-------------|-------------------|
| 1. Front bottom | 3. Back | 5. Deflector |
| 2. Back bottom | 4. Side | 6. Cast iron grid |
| | 7. Ash tray | |

BEF AQUATIC WH V 500 E

BlmSchV
Stufe 2

15a
B - VG

ČSN EN
13229

TECHNICAL DRAWING

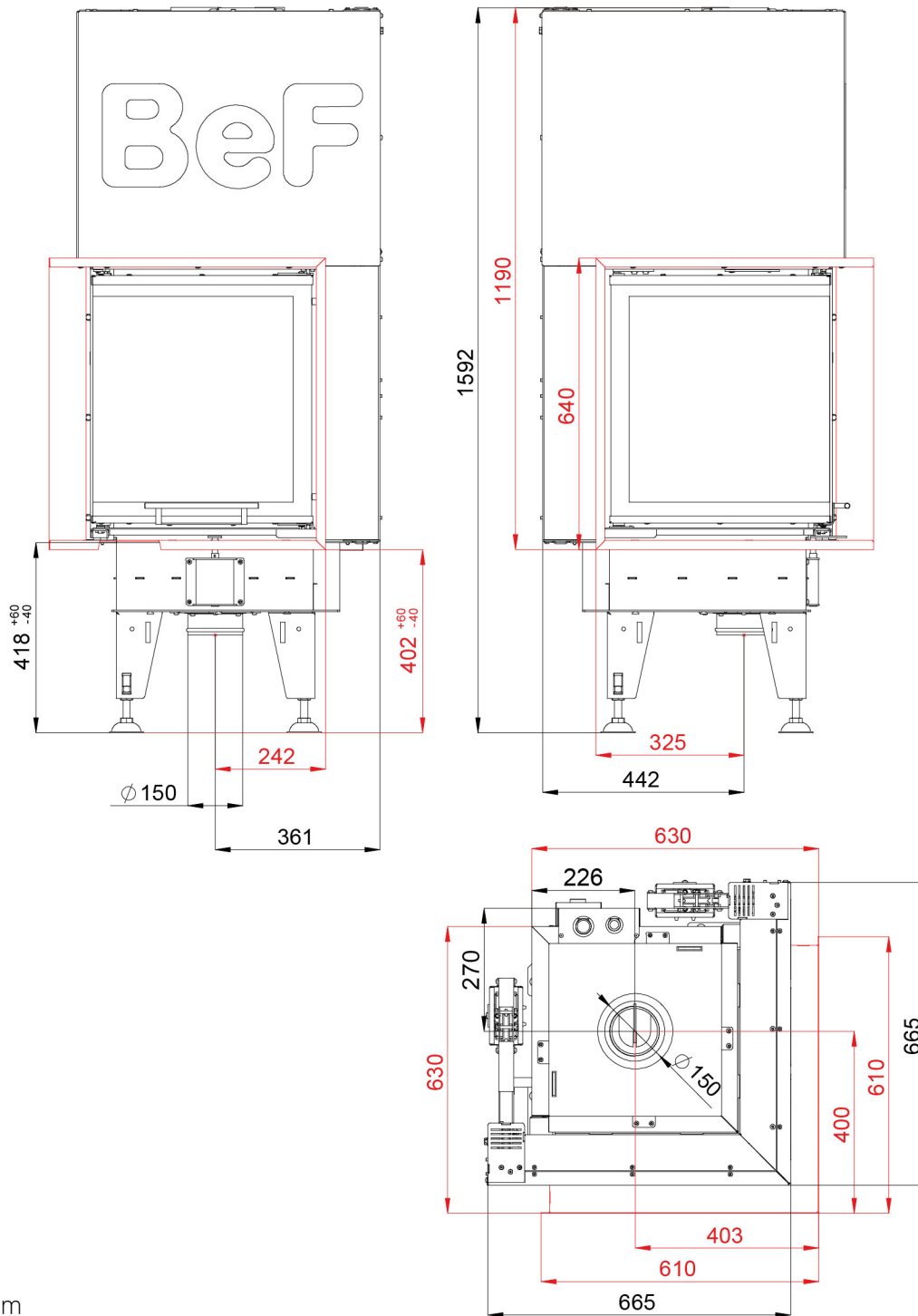

Glass

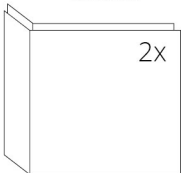

480 x 480 x 532 mm

BEF AQUATIC WH V 500 E

BlmSchV
Stufe 2

15a
B - VG

ČSN EN
13229

www.befhome.com