

SPECIFICATIONS

Rated thermal input	14,5 kW
Rated thermal input into water	4,8 kW
Efficiency	84 %
Smoke flue diameter	200 mm
Min. thrust (under pressure) for rated thermal input	12 Pa
Fuel gas temperature	213 °C
Volume of fuel gas	12,4 g/s
CO emissions in fuel gas (at 13 % O ₂)	0,0624 %
Dust in the fuel gas (at 13 % O ₂)	37 mg/Nm ³
Volume of fuel per hour	4,08 kg/h
Fuel	wood (beech logs)
Weight	255 kg



LIST OF SPARE PARTS

Heat exchanger connection diagram

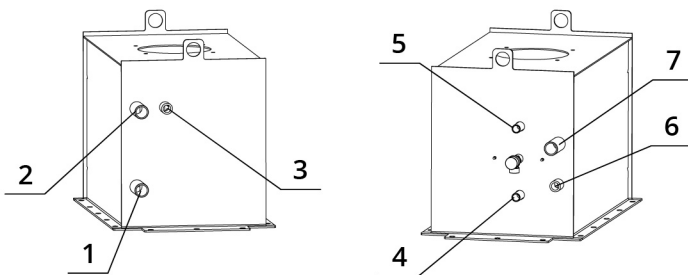

1. Cold water inlet to the heat exchanger (return), external thread 1"
2. Hot water outlet from the heat exchanger (riser), external thread 1"
3. Inlet for venting valve, internal thread 1/2"
4. Heated water outlet from thermal protection, external thread 1/2"
5. Cold water inlet to thermal protection, external thread 1/2"
6. Inlet for pressure relief valve, internal thread 1/2"
7. Thermal Input Sensor, external thread 1"

Carcon stones

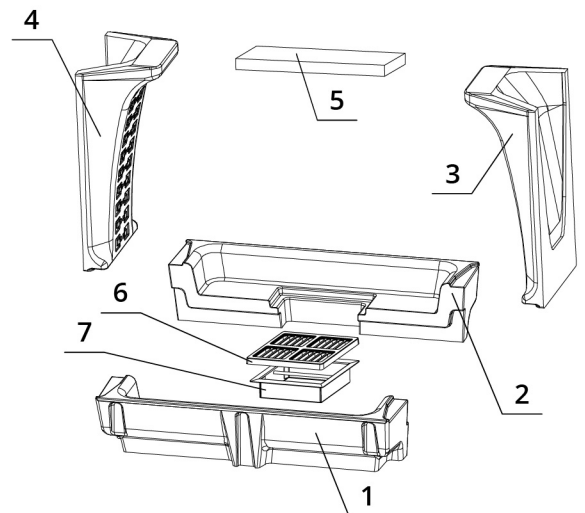

1. Front bottom
2. Back bottom
3. Right side
4. Left side
5. Deflector
6. Cast iron grid
7. Ash tray

BEF TWIN 8 AQUATIC II.

BImSchV Stufe 2	15a B - VG	ČSN EN 13229
--------------------	---------------	-----------------

www.befhome.com

TECHNICAL DRAWING

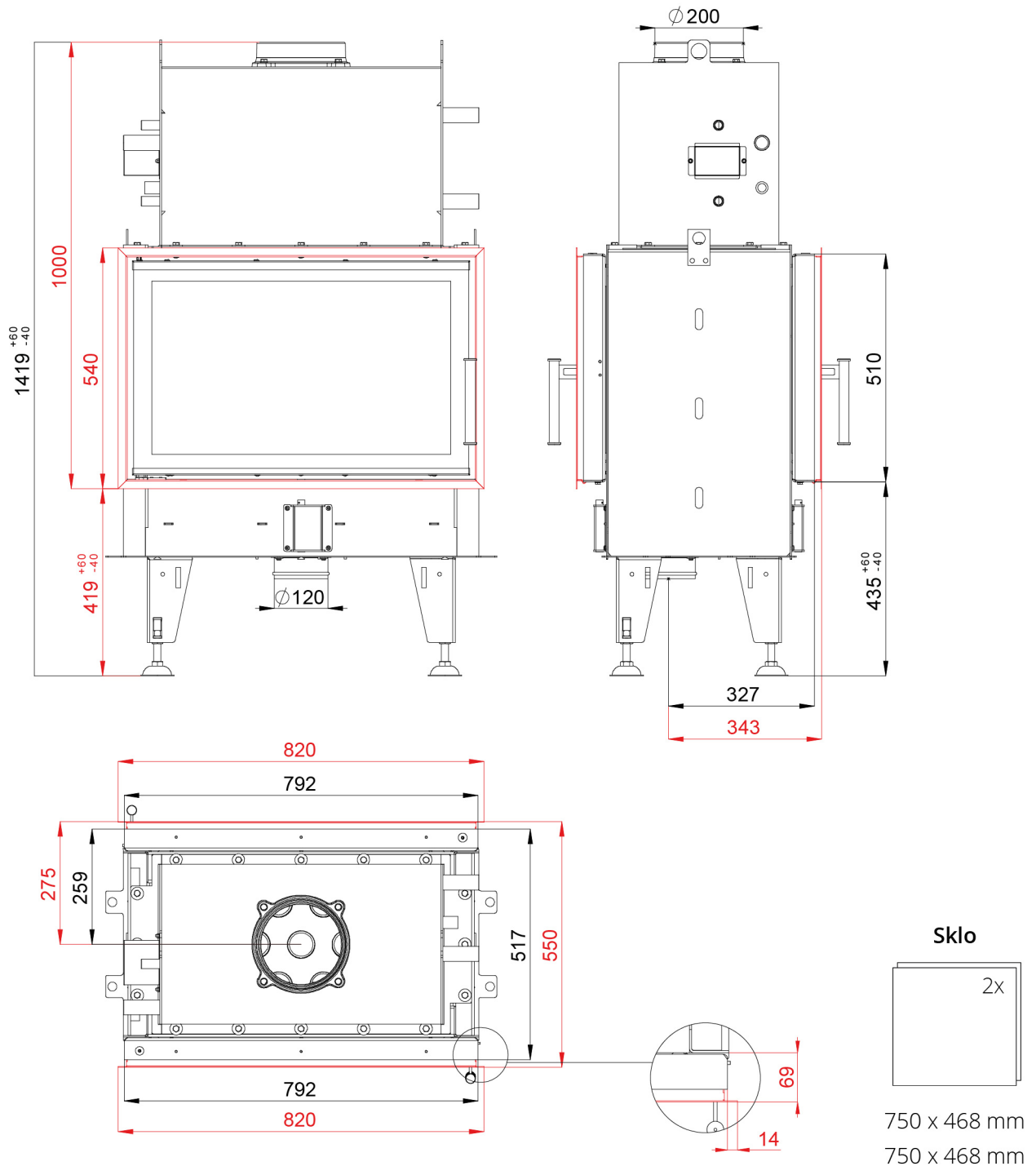

BEF TWIN 8 AQUATIC II.

BImSchV Stufe 2 | 15a B-VG | ČSN EN 13229

www.befhome.com