

BIOCLASS iC DX

Biomass boiler

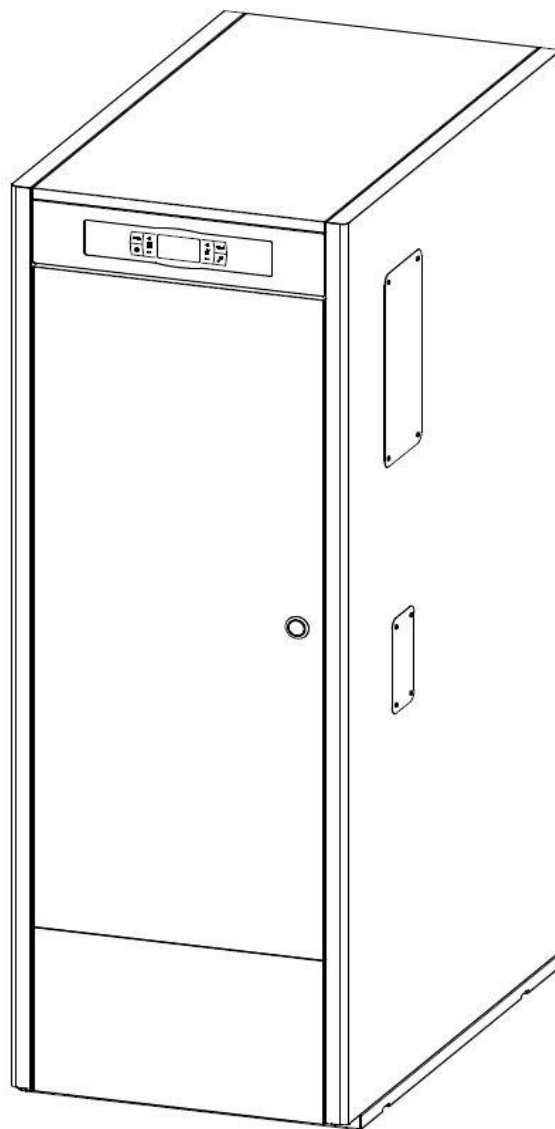

Thank you for choosing a DOMUSA TEKNIK heating boiler. Within the product range offered by **DOMUSA TEKNIK** you have chosen **Bioclass iC DX** model. With a suitable hydraulic installation and with a correct fuel, this boiler will provide the ideal level of comfort for your home.

This manual forms an essential part of the product and it must be given to the user. We recommend you read the warnings and recommendations in the manual carefully, as they contain important information on the safety, use and maintenance of the installation.

These boilers must be installed by qualified personnel only, in accordance with the legislation in force and following the manufacturer's instructions.

Commissioning of these boilers and any maintenance operations must only be carried out by **DOMUSA TEKNIK's** Authorised Technical Assistance Services.

Incorrect installation of these boilers could result in damage to people, animals or property, and the manufacturer will hold no liability in such cases.

DOMUSA TEKNIK informs all parties concerned that, in compliance with section 1 of the first additional provision of Law 11/1997, the responsibility for delivering packaging waste or used packaging for its proper environmental management will be that of the final owner of the product. At the end of its useful life, the product must be taken to a selected collection point for electrical and electronic equipment or must be returned to the distributor at the time of purchasing a new equivalent appliance. For more detailed information on the collection schemes available, contact either the collection facilities of the local authority or the distributor where the purchase was made.

ÍNDICE

1 LIST OF COMPONENTS.....	6
2 INSTALLATION INSTRUCTIONS	8
2.1 LOCATION	8
2.2 HYDRAULIC INSTALLATION.....	8
2.3 CYLINDER.....	9
2.3 FUEL.....	9
2.4 INSTALLING THE HOPPER.....	10
2.5 INSTALLATION OF A ROOM TEMPERATURE SENSOR OR THERMOSTAT	11
2.6 ELECTRICAL CONNECTION	11
2.7 COMBUSTION PRODUCT REMOVAL	12
2.8 BIO HYDRAULIC KIT INSTALLATION.....	13
2.9 LOSS OF PRESSURE IN THE BOILER.....	13
2.10 INSTALLATION WITH A BT BUFFER TANK (OPTIONAL).....	14
3 COMMISSIONING OF THE BOILER	17
3.1 PRIOR WARNINGS	17
3.2 FILLING THE INSTALLATION	17
3.3 INITIAL CALIBRATION OF THE FEED AUGER	17
3.4 COMMISSIONING.....	18
3.5 INSTALLATION DELIVERY	18
4 DIGITAL DISPLAY	19
5 OPERATION	22
5.1 "ONLY HEATING" OPERATION	22
5.2 OPERATING WITH A SANIT DHW TANK (OPTION)	22
5.3 BOILER TEMPERATURE SET POINT SELECTION.....	23
5.4 DHW SET TEMPERATURE SELECTION.....	23
5.5 SELECTING THE SETPOINT TEMPERATURE OF THE BUFFER TANK (ONLY WITH BUFFER TANK)	24
5.6 FUNCTIONING ACCORDING TO OUTDOOR TEMPERATURE CONDITIONS OTC (OPTION)	24
6 OPERATING WITH BIO HYDRAULIC KITS (OPTIONAL).....	25
7 OPERATION WITH A BT BUFFER TANK (OPTIONAL)	26
7.1 OPERATION WITH A TEMPERATURE SENSOR IN THE BT BUFFER TANK (P.08 = 2).....	26
7.2 OPERATION WITH A CONTROL THERMOSTAT IN THE BT BUFFER TANK (P.08 = 4).....	27
8 OPERATING WITH LAGO FB OT+ REMOTE CONTROL (OPTIONAL)	28
9 "ICONNECT" CONNECTIVITY	29
9.1 REQUIREMENTS FOR CONNECTING TO <i>ICONNECT</i>	29
9.2 BOILER REGISTRATION IN <i>ICONNECT</i>	30
9.3 DESCRIPTION OF THE <i>ICONNECT</i> APPLICATION	31
9.4 <i>ICONNECT</i> APP MAP	31
10 USER MENU.....	33
10.1 ASHTRAY STATUS	35
11 SETUP MENU	36
11.1 TIMERS PROGRAMMING PROCESS	37
11.2 HEATING TIME SCHEDULES.....	38
11.3 BOILER TIMER PROGRAMMING.....	38
11.4 CVS SUCTION SYSTEM TIMER PROGRAMMING (CVS SUCTION SYSTEM OPTION ONLY).....	39
11.5 DHW RECIRCULATION FUNCTION TIMER PROGRAMMING (DHW TANK OPTION ONLY)	39
11.6 TIME SETTING	39
11.7 ASHTRAY EMPTY WARNING FUNCTION	40
11.8 MANUAL SETTING OF FEED AUGER CALIBRATION	40
11.9 REGISTRATION OF THE BOILER IN <i>ICONNECT</i>	40
11.10 SCREEN CONTRAST SETTING.....	40
12 CALIBRATION MENU	41
12.1 FEED AUGER FILLING.....	42
12.2 FEED AUGER CALIBRATION	43
12.3 MANUAL SETTING OF FEED AUGER CALIBRATION	44
12.4 MANUAL ASH CLEANING ACTIVATION	44
12.5 MANUAL CIRCULATION PUMPS ACTIVATION.....	44

13 TECHNICAL MENU.....	45
13.1 ENTRY AND SET THE ACCESS CODE ("COD", P.25)	48
14 BOILER'S SETUP PARAMETERS	49
14.1 BOILER MODEL (P.01).....	49
14.2 BOILER HEAT OUTPUT (P.02, P.03)	49
14.3 GENERAL FAN SPEED FACTOR (P.04).....	49
14.4 FUEL FOR IGNITION (P.05)	49
14.5 FUEL CONSUMPTION (P.06).....	49
14.6 FUEL TYPE (P.07).....	49
14.7 MANAGING BT BUFFER TANKS (P.08, P.28, P.50)	50
14.8 AUXILIARY PARAMETER FOR FUEL SELECTION (P.26)	50
14.9 BOILER MINIMUM TEMPERATURE MODE (P.13, P.14)	50
15 HEATING CIRCUIT'S SETUP PARAMETERS	51
15.1 HEATING PUMP POST-CIRCULATION TIME (P.15)	51
15.2 BOILER'S PUMP OPERATING MODE (P.18).....	51
15.3 MINIMUM BOILER WATER PRESSURE (P.19)	51
15.4 MAXIMUM HEATING FLOW TEMPERATURE OF MIXED CIRCUITS (P.27)	51
15.5 TYPE OF ROOM TEMPERATURE DEVICE (P.46, P.47, P.48)	51
15.6 ROOM TEMPERATURE HYSTERESIS (P.49).....	52
15.7 ROOM TEMPERATURE CORRECTION (P.51, P.52, P.53)	52
16 DHW CIRCUIT'S SETUP PARAMETERS.....	53
16.1 LEGIONELLA PROTECTION FUNCTION (P.17).....	53
16.2 DHW RE-CIRCULATION FUNCTION (P.20 = 2)	53
17 ADDITIONAL FUNCTIONS.....	54
17.1 CVS SUCTION SYSTEM CYCLE TIME (P.22).....	54
17.2 RESET DEFAULT VALUES (P.24)	54
17.3 PUMPS ANTI-LOCK FUNCTION	54
17.4 ANTI-FROST FUNCTION.....	54
17.5 BOILER PRESSURE SENSOR FUNCTION	54
17.6 CONNECTING THE LAGO FB OT+ REMOTE CONTROL	54
17.7 ROOM THERMOSTAT CONNECTION	55
17.8 CONNECTING THE ROOM SENSOR.....	55
18 MULTI-FUNCTIONAL RELAY (P.20)	56
18.1 BOILER ALARMS EXTERNAL SIGNAL (P.20 = 1)	56
18.2 DHW RE-CIRCULATION FUNCTION (P.20 = 2)	56
18.3 AUTOMATIC WATER FILLING FUNCTION (P.20 = 3).....	56
19 CLEANING THE ASH DRAWER	57
19.1 SAFETY WARNINGS:	58
20 SAFETY LOCK-OUTS.....	59
20.1 WATER OVERHEAT SAFETY LOCK-OUT (E-11)	59
20.2 FUEL ENTRANCE TUBE OVERHEAT SAFETY CUT-OUT (E-05).....	59
20.3 LOW PRESSURE LOCK-OUT	60
21 SHUTTING DOWN THE BOILER	60
22 EMPTYING THE BOILER.....	60
23 BOILER MAINTENANCE	61
23.1 FREQUENCY OF MAINTENANCE OF THE BOILER AND CHIMNEY	61
23.2 BURNER CLEANING PROCEDURE	61
23.3 HEAT EXCHANGER CLEANING PROCEDURE.....	63
23.4 DRAINING THE CONDENSATE WATER.....	64
23.5 BOILER WATER CHARACTERISTICS.....	64
23.6 DHW CHARACTERISTICS	64
24 DIAGRAMS AND MEASUREMENTS	65
25 CONNECTIONS DIAGRAM	67
25.1 BOILER.....	67
25.2 BURNER.....	68
26 ELECTRICAL DIAGRAM	69
27 TECHNICAL DATA	70
28 ALARM CODES.....	72

1 LIST OF COMPONENTS

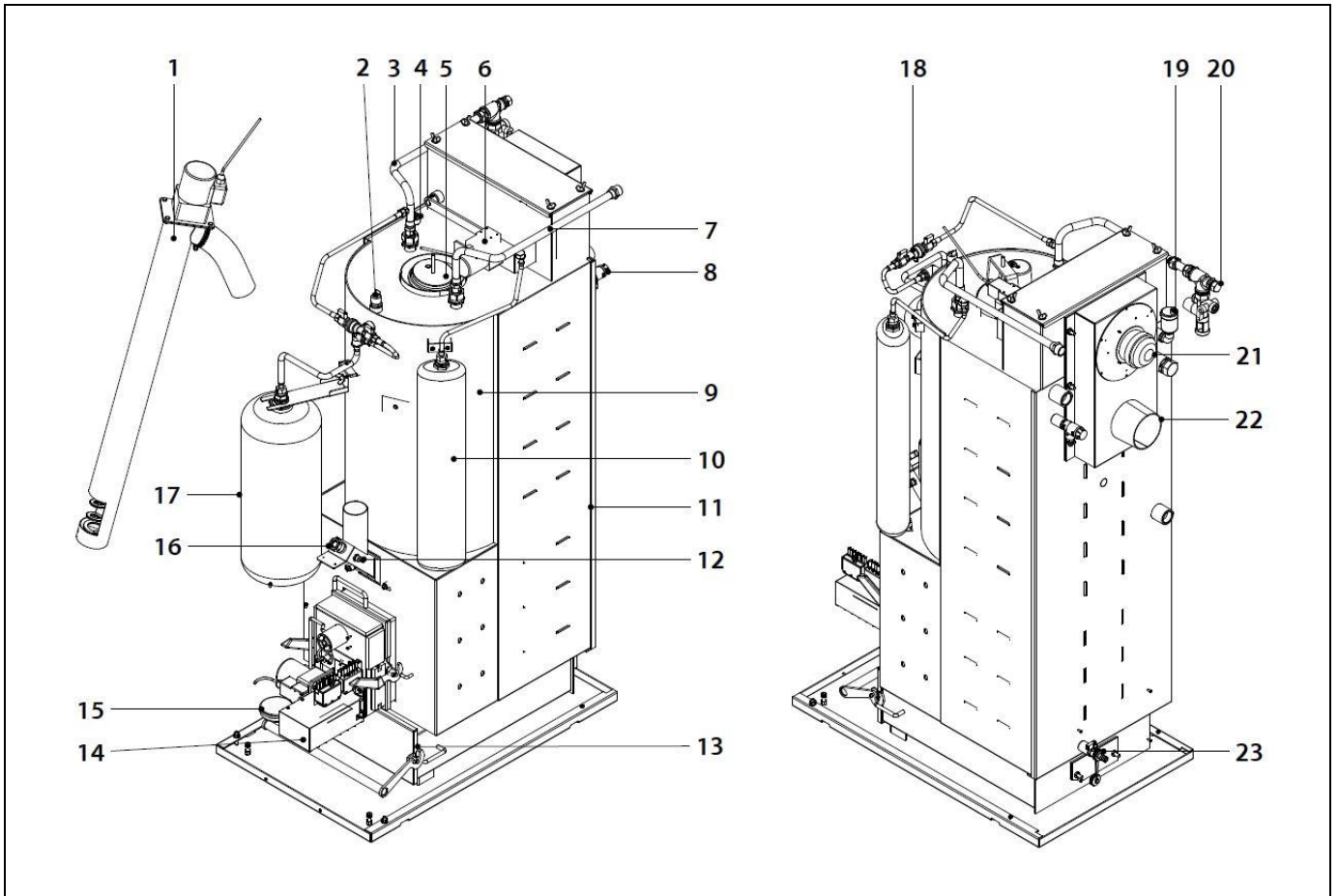

- | | |
|--|-------------------------------------|
| 1. Pellet Auger. | 13. Ash pan. |
| 2. Water pressure sensor. | 14. Burner. |
| 3. DHW Inlet. | 15. Air pressure sensor. |
| 4. Boiler bulb holder sheath. | 16. Viewport. |
| 5. DHW bulb holder sheath. | 17. Boiler expansion vessel. |
| 6. Heat exchanger cleaning mechanism. | 18. Filling loop. |
| 7. DHW outlet. | 19. Automatic air vent. |
| 8. Safety valve. | 20. DHW safety valve. |
| 9. Stainless steel Tank in tank system. | 21. Exhaust fan. |
| 10. Heating expansion vessel. | 22. Chimney connection. |
| 11. Heat Exchanger. | 23. Drainage valve. |
| 12. Pellet inlet thermostat. | |

Control components

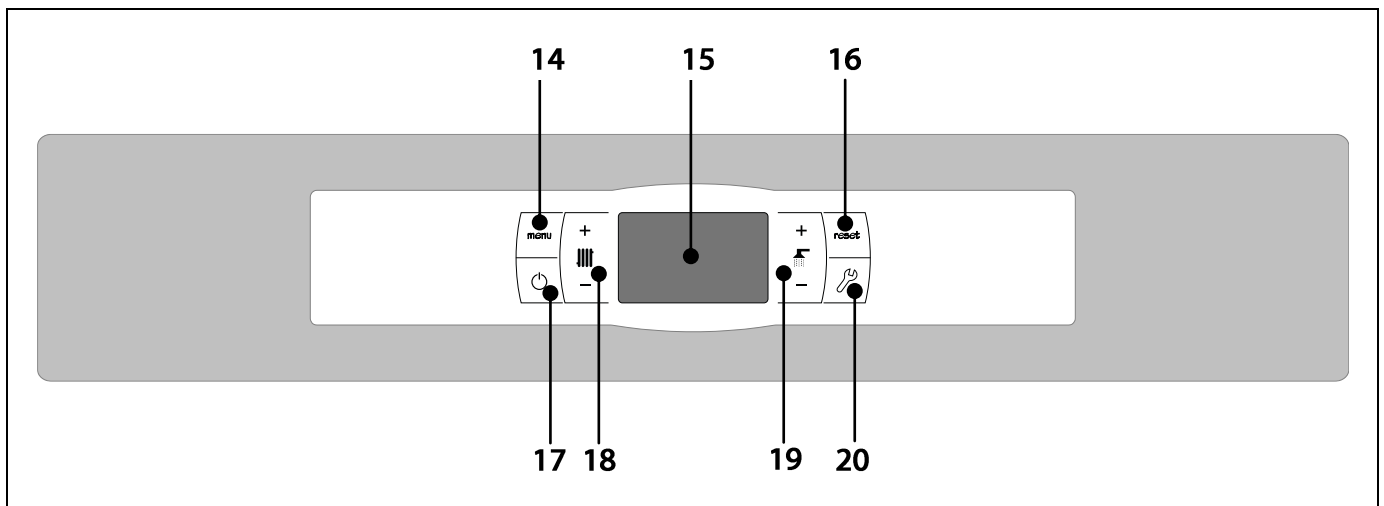

14. MENU touch button:

This button is used to access and browse through the "User Menu".

15. Digital display:

It is the main boiler functioning display, on which all the operating information, settings and values appear. This display is also used to access the appliance's user and service settings. In standard operating mode (default display), the actual boiler temperature is shown. If malfunction occurs, an alarm code will appear on the digital display instead of the temperature.

16. RESET touch button:

This button is used to restore functioning of the boiler after a lock-out situation. Also it is used to exit from any of the menus or parameters of the boiler without saving it and to return to the previous menu level.

17. ON touch button:

This button switches on and off the boiler.

18. Heating temperature touch button:

Use this button to select the desired boiler, room temperature and other options related to the heating installation. It can also be used to disable the hot water function.

19. DHW set temperature touch button:

Use this button to select desired DHW SET temperature. It can also be used to deactivate DHW service.

20. SET touch button:

This button is used to access and browse through the "Setup menu". Touch this button to access the settings options.

2 INSTALLATION INSTRUCTIONS

The boiler must be installed by personnel authorised by the Ministry of Industry, in compliance with the applicable laws and regulations.

This boiler is suitable for heating water to a temperature below boiling point at atmospheric pressure. It must be connected to a heating installation and/or a domestic hot water distribution network, which must always be compatible with its performance and power.

This appliance must only be used for the purpose for which it has been expressly designed. Any other use is considered unsuitable and therefore hazardous. The manufacturer shall not be considered liable under any circumstances for damage caused by unsuitable, erroneous or irrational use.

Remove all the packaging and check the contents are complete. In case of doubt, do not use the boiler. Contact your supplier. Keep the packaging elements out of reach of children, as they can be dangerous.

When you no longer wish to use the boiler, disable the parts that could be a potential source of hazard.

2.1 Location

The boiler must be installed in a sufficiently ventilated site, away from humidity. It must be located so that the air grilles on the premises are not obstructed and normal boiler maintenance is possible even if it is placed between items of furniture. One metre of free space must be left above the boiler for this purpose. In the case of locating the boiler between furniture or walls, the reserve tank with the feeder must be previously installed next to the boiler.

If you want to connect the boiler to the **iConnect** Internet platform or register it in the **iConnect** user application, there must also be **coverage of the home's Wi-Fi network** in the room where the boiler is located.

2.2 Hydraulic installation

The hydraulic installation must be made by qualified personnel. The applicable installation legislation is to be complied with, and the following recommendations should also be taken into account:

- The inside of the installation piping should be thoroughly cleaned before switching on the boiler.
- We recommend inserting cut-off valves between the installation piping and the boiler to simplify maintenance tasks.
- Leave a free space around the boiler for carrying out any maintenance and repair operations.
- Drain valves and suitable devices for correctly bleeding the air from the circuit during the boiler filling stage should be fitted.
- Install all the necessary safety elements (expansion vessel, safety valve, etc.) to comply with the applicable regulations for the installation.
- If the boiler is installed at a lower height than the heating installation, it is recommendable to create a siphon at the boiler outlet, to prevent the installation from heating up due to natural convection when heating is not required.

2.3 Cylinder

The special heat generator-cylinder conception and the regulation in force, oblige to comply with the following requirements:

- Secondary circuit (or DHW circuit) will need to have a 7 bar safety valve.
- Place dielectric sleeves on the appliance connections when the main pipe is cooper.
- Safety valve evacuation hose need to be led to a drain.
- When water supply pressure is over 7 bar, a pressure reducer needs to be installed.

NOTE: Bioclass iC DX boilers are equipped with a DHW safety group (tared at 7 bar), dielectric sleeves and a DHW expansion veesel, with the objective of avoiding the dripping from the DHW safety valve.

IMPORTANT: The outlet temperature of the DHW can be high. DOMUSA TEKNIK offers a hydraulic kit with a mixing valve that allows the selection of the desired DHW temperature.

2.3 Fuel

Bioclass iC DX boiler must be fuelled by **DIN PLUS** certified wood pellet. The **DIN PLUS** or **EN PLUS A1** certificate assures that the fuel's humidity levels and calorific value are ideal for optimum boiler functioning. If this requirement is not complied with, **DOMUSA TEKNIK's** guarantee of the appliance will automatically be null and void.

The following aspects must be taken into account for the correct storage of fuel:

- Wood pellets should be stored in a room protected from humidity and weather. It is important to create an air gap around the wood pellet bags to ensure good ventilation. These bags should never be stored directly in contact with the ground and / or a wall.
- Wood pellets must be handled with care, as mixing them in bags can damage them.
- Wood pellets must be visually inspected before use in the boiler, to ensure the absence of dust or pellets crushed in large quantities, which could cause a boiler malfunction.

2.4 Installing the hopper

DOMUSA TEKNIK supplies a hopper for storing the pellets with the boiler. The tank is reversible and can be mounted on either the left or right side of the boiler. It is also equipped with adjustable feet for height regulation.

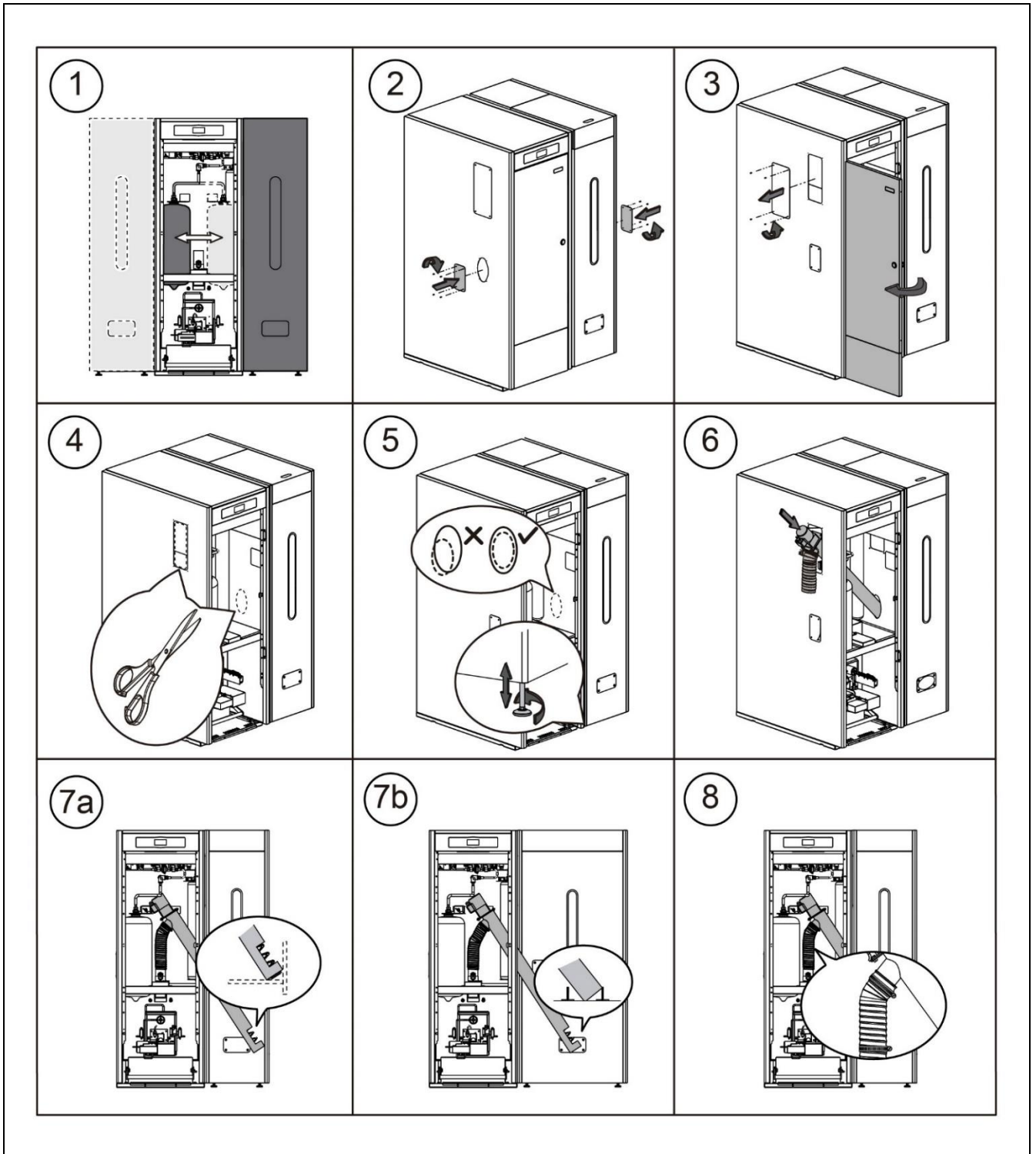

IMPORTANT: Ensure the height of the elliptical holes on the sides of the boiler and on the hopper coincide, for correct insertion of the feed auger. To do this, make the necessary adjustments for height (using the adjustment feet) and depth (correctly positioning the hopper).

2.5 Installation of a room temperature sensor or thermostat

The **Bioclass iC DX** boiler has a **TA₁ (J6)** *terminal strip* (see "*Connection Diagrams*"), prepared for the connection of a device to measure the temperature conditions inside the house, which will manage the remote control of the heating circuit.

These devices will need to be suitably located within the home to be able to correctly manage the comfort of the house. It is advisable to install them in an area of the home that has regular use (living room, master bedroom, or similar), if possible avoiding rooms where heat or cold could be generated, such as kitchens, bathrooms, refrigerated larders, etc. In turn, they must be installed at a medium height and as far as possible from any source of heat or cold that could distort the temperature reading, such as windows, fireplaces, stoves, etc.

Two different types of devices can be connected to the **Bioclass iC DX boiler**:

Room sensor

The room sensor measures the temperature inside the home and transmits it to the boiler which displays it on the screen. The user will be able to select the desired setpoint temperature at any time from the "User" menu, and will have the possibility of adjusting the desired comfort times for the installation from the "Heating time programming" (see "*Configuration Menu*"). The electronic control of the boiler will manage the operating conditions to achieve the desired comfort and will modulate the boiler temperature to optimise the operation and efficiency of the heating installation.

For the correct connection of a room sensor to the **Bioclass iC DX** boiler, proceed as follows:

- Unplug the boiler from the mains.
- Connect the room sensor, supplied with the boiler, to the TA1 (J6) terminal strip (see "*Connection Diagrams*"). The bridge that connects the terminals of said strip must be removed first.
- Reconnect the boiler to the mains power.
- The boiler must be configured to operate with "Room Sensor", setting parameter **P.46** to **1** (see "Technical Menu").
- The electronic control allows correcting the value measured by the room temperature sensor, using parameter **P.51**. To make this adjustment correctly, first of all it should be waited a minimum of 10 minutes for the measured value to stabilize (without touching the room temperature sensor).

Room thermostat

A room thermostat connected to the boiler will activate and deactivate the heating demand depending on its setting. In addition, if it has a time programming (chronothermostat), the user can set the desired heating operating periods.

For the correct connection of a thermostat to the **Bioclass iC DX** boiler, proceed as follows:

- Unplug the boiler from the mains.
- Connect the room thermostat to the terminal block **TA1 (J6)** (see "*Connection Diagrams*"), having previously removed the bridge that connects the terminals of said strip.
- Reconnect the boiler to the mains power.
- The boiler comes factory configured for the connection of a "Room Thermostat". If for any reason this is not the case, for its correct configuration, parameter **P.46** must be set to **0** (see "Technical Menu").

2.6 Electrical Connection

The boiler is equipped for connection at 230 V~, 50 Hz. **The socket should have an appropriate earth connection.**

The terminal strip **J2** includes terminals for connecting the feed auger, whereas the terminal strip **J3** includes terminals for connecting the circulation pump of the boiler (**BC**).

IMPORTANT: Before carrying out any work on the boiler's electrical installation, always ensure it is disconnected from the mains.

2.7 Combustion product removal

Bioclass iC DX boiler is a biomass boiler and it is essential for it to be connected to a flue, i.e. a smoke duct able to create a pressure drop (which in this case should be between 0,05 and 0,20 mbar), in compliance with the applicable laws to this regard.

The combustion product exhaustion ducts must be installed by qualified personnel and must comply with the regulations in force. For the flue to create a pressure drop, the following recommendations should be taken into account:

- It should be suitably insulated.
- It should be independently located, with a separate flue for each boiler.
- It should be vertical, avoiding any angles greater than 45°.
- It should always have the same diameter. It is recommendable for it to be circular, and never any narrower than the boiler outlet.
- It is obligatory to install a fume inspection plate with condensation collection, to remove the condensation generated in the flue. Otherwise, the condensation may reach the inside of the boiler and cause irreparable damage, which would not be covered by **DOMUSA TEKNIK's** guarantee. The condensation pipe should lead to a drain outlet, as a large amount of water may be generated. This connection must be made in compliance with the regulations for draining off condensation water to the drain network.

2.8 BIO hydraulic kit installation

In option a **BIO hydraulic kit**, within the kits range offered by **DOMUSA TEKNIK**, could be connected to **Bioclass iC DX** boiler. In that way the features of the boiler will be increased.

Look at the following instructions for a correct installation:

- Unplug the boiler and the hydraulic kit from the main power supply.
- Connect the communication between the boiler and the hydraulic kit, connecting the **J4** electrical strips of both devices (see "Connection Diagrams"), for which, you must use a 2-wire electrical hose and the 2-way strip (**+ A / -B**) supplied together with the Kit (in the documentation bag). **To assure the correct running of BIO hydraulic Kit it is essential to respect the polarity of the connection. The same wire must be connected to the +A terminal of the boiler as well as to the +A terminal of the hydraulic Kit. Same operation with the -B terminals.**
- After connecting the communication between the boiler and the hydraulic Kit, plug the **BIO hydraulic Kit** to the main power supply. It is recommended to plug the Kit before the boiler to assure a correct running of the system.
- Plug the boiler to the main power supply.

Follow the instructions provided with the kit to assure a correct installation.

IMPORTANT: It is compulsory to respect the polarity of both wires of the cable to assure a correct running of BIO hydraulic Kit.

NOTE: In order to have a correct communication between the boiler and the BIO Hydraulic Kit, it is necessary to connect first the Kit to the mains and then the boiler.

2.9 Loss of pressure in the boiler

To correctly size the hydraulic installation and choose the correct pump operation and pump operation curves, the pressure loss caused by the boiler should be taken into account. The following graph describes the pressure loss curves according to the model of **Bioclass iC DX** boiler:

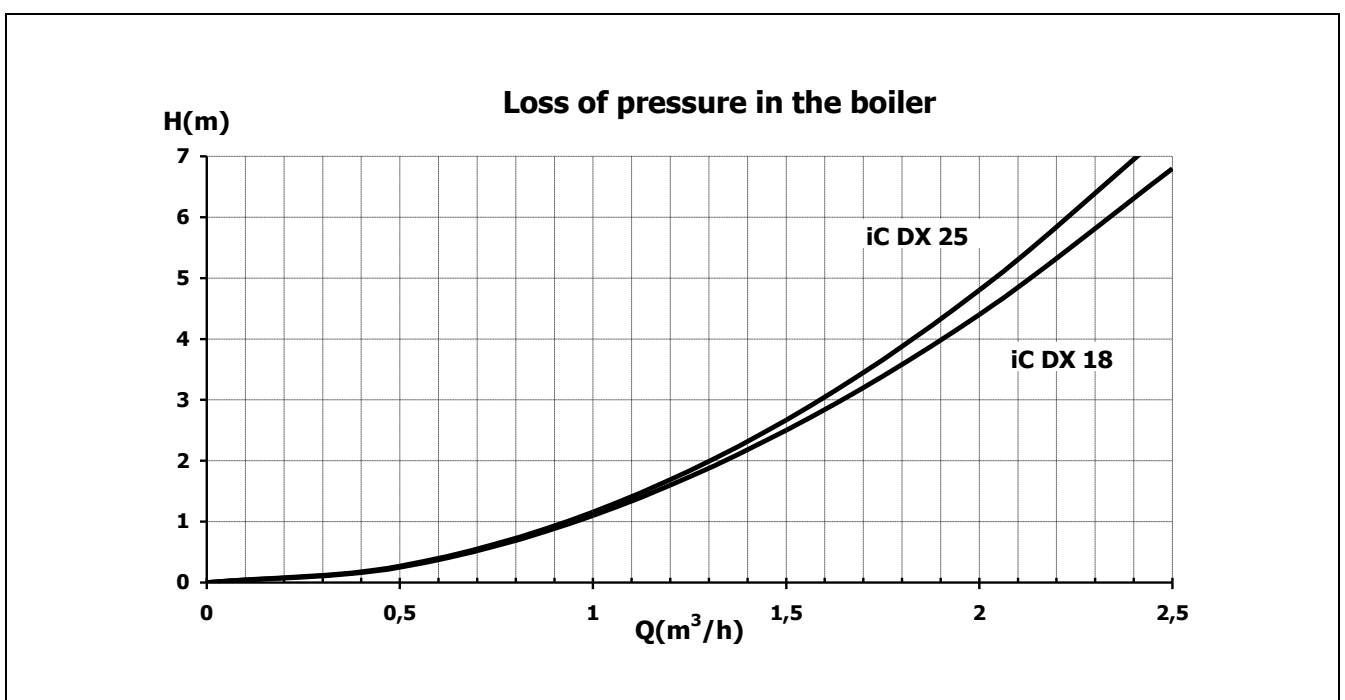

2.10 Installation with a BT Buffer Tank (Optional)

The **Bioclass iC DX** boiler can be accompanied by a **BT Buffer Tank** during the installation from the wide range offered by DOMUSA TEKNIK, which may increase the benefits provided by the boiler in the heating service.

For this reason, the electronic control of the boiler is equipped with an input for a temperature sensor or a temperature thermostat (**Sbt**; terminals 18-19 on connection strip **J7**) and a circulation pump output (**Bbt**; terminals N-7 on the connection strip **J2**) dedicated exclusively to managing the heating of the buffer tank. Using these control elements of the boiler you will be able to manage 2 different modes of buffer tank hydraulic installation. The installation type will be selected using parameter **P.08** in the "Technician" menu on the control panel.

The boiler is supplied with this installation option disabled. To enable it, the electrical resistance (**Rbt**) connected between terminals **18** and **19** of connection strip **J7** (see "*Connection Diagram*") must be disconnected and replaced with a temperature sensor (supplied as an option by DOMUSA TEKNIK) or a control thermostat installed in the BT buffer tank. After disconnecting the resistance in the "Technician" menu of the control panel, parameter **P.08** must be enabled, via which you can select the installation mode desired.

The following sections describe in detail the hydraulic and electrical connection characteristics for each installation mode.

2.10.1 Installation with Sanit DHW tank before BT tank and control by temperature sensor (P.08 = 2)

In this installation mode, all heating circuits must be hydraulically connected to the BT buffer tank, upstream from the BT buffer tank. The BT tank feed pump (**Bbt**) will be installed as indicated in the following hydraulic diagrams. The temperature of the BT tank is controlled and managed by a temperature sensor (**Sbt**) immersed in the buffer tank and electrically connected to the boiler. The temperature sensor is optionally supplied by **DOMUSA TEKNIK** and it can be purchased at any warehouse specialized in heating supplies.

After the hydraulic installation of all the system components, proceed as follows to carry out the correct electrical connection of the BT buffer tank to the **Bioclass iC DX** boiler:

- Unplug the boiler from the mains power.
- Disconnect the electrical resistance (**Rbt**) connected between terminals **18** and **19** of connection strip **J7** (see "*Connection Diagram*").
- Connect the BT tank temperature sensor (supplied optionally) to the sensor connection strip **J7** (**Sbt**; terminals **18** and **19**) (see "*Connection Diagram*").
- Insert the temperature sensor bulb in the bulb-holder sheath provided in the buffer tank.
- Connect the BT tank feed pump to the component connection strip **J2** (**Bbt**; terminals **N** and **7**) (see "*Connection Diagram*").
- Connect the boiler to the mains power.
- Using the control panel, access parameter **P.08** in the "Technician" menu (see "*Technician Menu*") and set the value to "**2**".
- After that, if it is necessary, set also the parameter **P.28** "BT buffer tank temperature hysteresis".

Once the hydraulic and electrical connection described above has been completed, to adjust and configure the BT buffer tank operation, carefully read the section "*Operation with a BT buffer tank*" in this manual.

2.10.2 Installation with BT tank and control by thermostat (P.08 = 4)

In this installation mode, all heating circuits must be hydraulically connected to the BT buffer tank. In other words, the BT buffer tank, the BT tank feed pump (**Bbt**) will be installed as indicated in the following hydraulic diagrams. The temperature of the BT tank is controlled and managed by a thermostat (**Tbt**) installed and immersed in the buffer tank and electrically connected to the boiler. The temperature control thermostat is not supplied by **DOMUSA TEKNIK** but can be purchased at any specialist central heating supplies warehouse.

After the hydraulic installation of all the system components, proceed as follows to carry out the correct electrical connection of the BT buffer tank to the **Bioclass iC DX** boiler:

- Unplug the boiler from the mains power.
- Disconnect the electrical resistance (**Rbt**) connected between terminals **18** and **19** of connection strip **J7** (see "*Connection Diagram*").
- Connect the **NC** contact (normally closed) on the BT tank control thermostat on the sensor connection strip **J7** (**Sbt**; terminals **18** and **19**) (see "*Connection Diagram*").
- Insert the thermostat bulb into the bulb-holder sheath provided in the buffer tank.
- Connect the BT tank feed pump to the component connection strip **J2** (**Bbt**; terminals **N** and **7**) (see "*Connection Diagram*").
- Connect the boiler to the mains power.
- Using the control panel, access parameter **P.08** in the "Technician" menu (see "*Technician Menu*") and set the value to "**4**".

Once the hydraulic and electrical connection described above has been completed, to adjust and configure the BT buffer tank operation, carefully read the section "*Operation with a BT buffer tank*" in this manual.

3 COMMISSIONING OF THE BOILER

3.1 Prior warnings

Repair and maintenance of the boiler must be carried out by a qualified professional, authorised by **DOMUSA TEKNİK**. For optimum functioning and conservation of the boiler, it should be serviced annually.

Carefully read this instruction manual and keep it in a safe, easily accessible place. **DOMUSA TEKNİK** will not be liable for any damages caused by failure to follow these instructions.

Before any servicing, disconnect the boiler from the mains.

3.2 Filling the installation

The hydraulic installation must include a disconnecter key, drain valves and the necessary hydraulic components for correctly filling the installation. **Before filling the primary circuit, make sure that the secondary (DHW circuit) is full.**

To fill the installation, open the fill valve until the parameter "*Water pressure*" of "*User Menu*" shows a pressure of 1 - 1.5 bars. The installation must be filled slowly, bleeding the air from the water circuit using the drain valves provided on the same. Close the fill valve after filling.

Bioclass iC DX boilers have a pressure sensor for controlling the pressure of the installation. If the installation does not have the minimum pressure set at **P.19** parameter of "*Technical Menu*" (by default 0.5 bar), a low pressure alarm will appear ("**E-19**").

IMPORTANT: Switching on the boiler with no water inside could result in serious damage.

3.3 Initial calibration of the feed auger

Bioclass iC DX boiler is equipped with a feed auger to supply the fuel. Follow the instructions described in "*Installing the hopper*" section to install it correctly. Due to diversity of feed augers and the range of different hoppers, it is needed to calibrate the feed auger minimum twice to assure the correct running.

Follow the instructions described in "*Feed auger calibration*" section of "*Setup menu*" to assure a correct calibration.

3.4 Commissioning

In order for the **guarantee to be valid**, the boiler must be commissioned by **personnel authorised by DOMUSA TEKNIK**. Before beginning the commissioning, the following must be complied with:

- The boiler must be plugged in to the mains.
- The installation must be filled with water (the pressure must be between 1 and 1.5 bar).
- The hopper must be filled with fuel.

The commissioning sequence is as follows:

- Check the flue is correctly installed using a condensation inspection tap and a draught stabiliser.
- Check the hopper and the feed auger are correctly installed. **The feed auger must be calibrated for a correct boiler functioning** (See "*Calibrating the feed auger*"). Check the right type of fuel is being used (wood pellet must be **DIN PLUS**).
- If the installation has flow and return valves, check they are open.

3.5 Installation delivery

After commissioning, the Technical Assistance Service will explain to the user how the boiler functions, making any observations they consider relevant.

The installer is responsible for clearly explaining to the user the functioning of any control or regulation device forming part of the installation but not supplied with the boiler.

Upon delivery of the boiler, the user receives the following documents:

- The boiler installation and operation manual.
- Combustion analysis performed during commissioning.
- The commissioning sheet.

4 DIGITAL DISPLAY

Bioclass iC DX boiler is equipped with a digital touch display for viewing and adjustment of the different boiler settings. The display has various display areas where different icons and numbers appear to indicate the different status of the boiler.

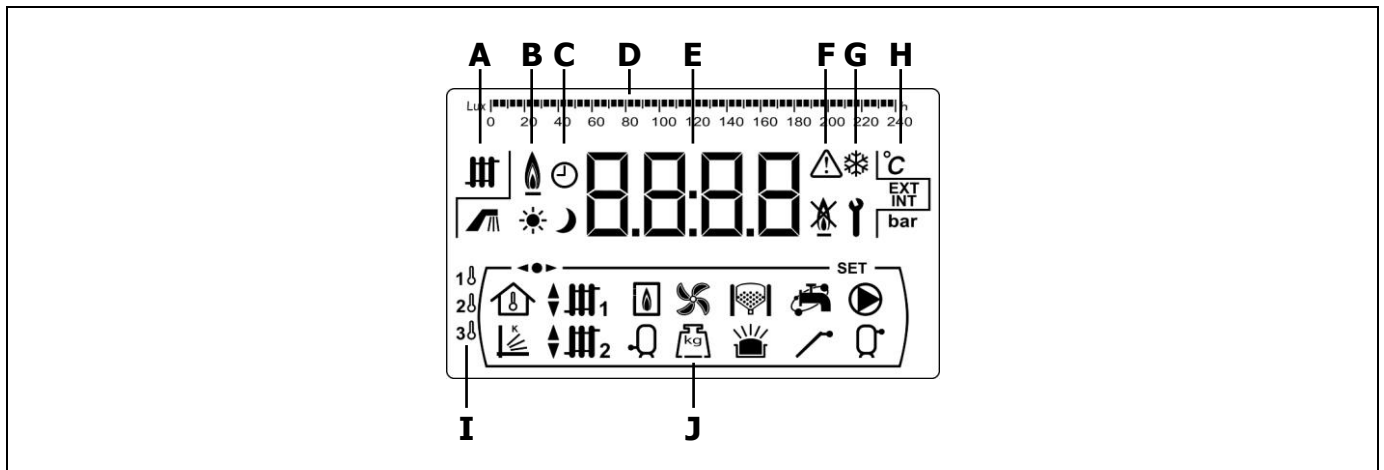



A Boiler status:  Heating function enabled.
 DHW production enabled.

B Icon for flame detection:  Flame detected.

C Timer icons:

 It is displayed when the real time is inside "ON" programmed period.

 It is displayed when actual time is inside "OFF" programmed period.

 When any screen is displayed it relates to the display of actual time, programming, etc.

D Scale marking bar: The meaning can change depending on the parameter displayed:

Time scale: Used to indicate values or settings related to the time and/or time programming:



Lux scale: Used to indicate the **lux level** read by the flame sensor:

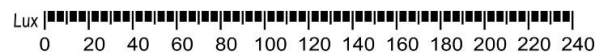

Ash Scale: Used to indicate the **level of ash**:



E Numerical digits.

F Alarm icons:  Warning.
 Boiler lock-out.

G Special functions icons:

 **Anti-frost function:** This icon blinks when the boiler's anti-frost function is activated.

 **Technical icon:** It is displayed when any of the boiler's technical parameter on the "Technical Menu" or "Setup menu" is displaying or modifying.

H Auxiliary icons.

°C Value or setting related to a temperature is shown by the numerical digits.

EXT Value or setting related to the outside temperature is shown by the numerical digits.

INT Value or setting related to the room temperature are shown by the numerical digits.

bar Value or setting related to the boiler water pressure is shown by the numerical digits.

I Heating zone icons:

 Display of any value or parameter related to Zone 1 heating.

 Display of any value or parameter related to Zone 2 heating.

 Display of any value or parameter related to Zone 3 heating.

J Operating mode icons:

 Display of any value or parameter related to the inside temperature of the home or parameters related to room sensors or remote controls.

 It is displayed when a value or setting related to OTC operating mode is shown by the numerical digits.

 It is displayed when the direct heating circuit n° 1 demand is activated or when a value or setting related to this circuit is shown by the numerical digits.











 It is displayed when the direct heating circuit n° 2 demand is activated or when a value or setting related to this circuit is shown by the numerical digits.

 It is displayed when the mixing heating circuit n° 1 demand is activated or when a value or setting related to this circuit is shown by the numerical digits. The arrows appear according to the 3 way mixing valve of the circuit activation mode. The upper arrow indicates that the hot channel of the valve is opening, and the lower arrow indicates that the hot channel of the valve is closing.

 It is displayed when the mixing heating circuit n° 2 demand is activated or when a value or setting related to this circuit is shown by the numerical digits. The arrows appear according to the 3 way mixing valve of the circuit activation mode. The upper arrow indicates that the hot channel of the valve is opening, and the lower arrow indicates that the hot channel of the valve is closing.

 It is displayed when any value or setting **related to the boiler and/or the burner** is shown by the numerical digits.

 It is displayed when a value or setting related to DHW tank is shown by the numerical digits.

-  It is displayed when a value or setting related to boiler's fan is shown by the numerical digits.
-  It is displayed when a value or setting related to weight, calibration, fuel consumption, etc. is shown by the numerical digits.
-  It is displayed when a value or setting related to the **CVS Suction System** is shown by the numerical digits.
-  It is displayed when a value or setting related to the burner's ash cleaning system or boiler's ashtray (either manual or compressor) is shown by the numerical digits.
-  It is displayed when a value or setting related to the ashtray overflowing is shown by the numerical digits.
-  Display of any value or parameter related to boiler connectivity in **iConnect**.
-  It is displayed when a value or setting related to DHW recirculation function is shown by the numerical digits. It displays blinking when the DHW recirculation pump is switched on.
-  It is displayed when the feed auger is switched on and it is displayed blinking when it is in manual operation mode.
-  Display of direct circuit No. 1 demand activated or when any value or parameter related to it is displayed.
-  Display of any value or parameter related to the temperature or operation of the buffer tank.
-  It is displayed when any of the "Menu" is in browse mode.
- SET** It is displayed when the parameter shown by the numerical digits is adjustable and it is displayed blinking when the parameter is in adjustment mode.

5 OPERATION

Bioclass iC DX is set by default as an "Only Heating" boiler (Heating zone 1). In option, it is possible to connect a BIO Hydraulic Kit to increase the features offered by **DOMUSA TEKNIK**.

5.1 "Only heating" operation

In this operation mode, it is needed to set a temperature of the boiler (see "*Boiler temperature set point selection*"), of the room thermostat (**TA1**) or of the **LAGO FB OT+** remote control (if there is any connected) in order to start the boiler up. The burner will start running to heat the water of the boiler. When the temperature of the boiler overtakes 60 °C, the heating pump is switched on to heat the water of the installation. The burner modulates the heat output level to maintain the set point temperature selected and the pump continues running until the installation reaches to the temperature selected in the room thermostat or remote control (if there is any connected). When the temperature in the boiler overtakes 4 °C the boiler set point temperature the burner stops until the temperature decreases 10 °C behind the set point temperature, in this moment the burner is switched on again.

It is possible to disable the heating service (**Summer** mode) by setting to "**OFF**" the boiler temperature set point. In this operating mode only the DHW service is available.

NOTE: When the heating service is disabled, they will be disabled all the circuits of the BIO Hydraulic Kit, if there is any connected.

5.2 Operating with a Sanit DHW tank (Option)

La caldera **BioClass iC DX** lleva incorporado un acumulador para la obtención de Agua Caliente Sanitaria.

In this operating mode, desired DHW SET will need to be chosen (see DHW Set selection). Burner will be turned on and when the DHW cylinder reaches the SET temperature, the boiler will return to be ready to heat the heating installation activating the heating mode. The modulating burner will maintain the SET boiler temperature. The heating pump will stop when the room temperature is the same or higher than the chosen in the room sensor device.

It is possible to disable the DHW by setting to "**OFF**" the DHW temperature set point.

NOTE: To assure the optimal DHW service, the heating service will not be available while the DHW service is activated to heat the DHW tank.

5.3 Boiler temperature set point selection

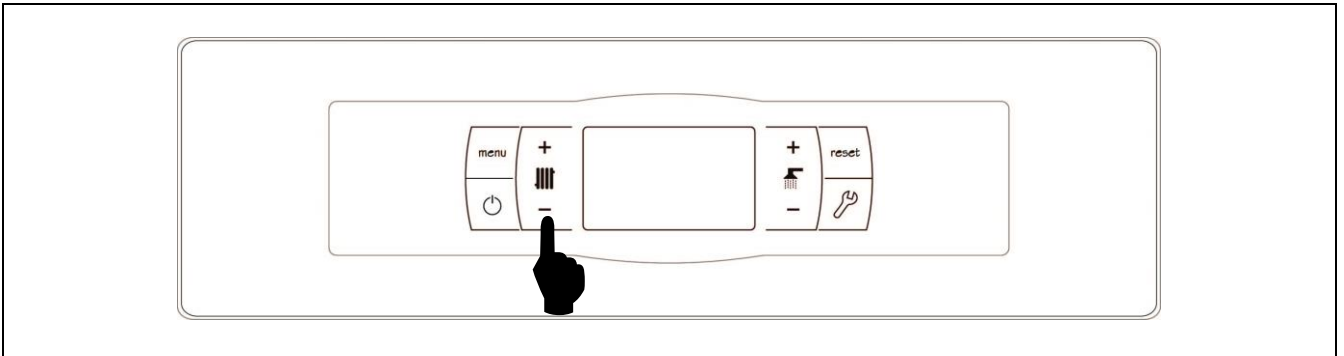

Boiler temperature set point selection is made by the tactile selector shown in the picture. Press "+" and "-" buttons to increase or decrease the set point desired. Few seconds after the desired set point temperature is adjusted the display returns to main position. The range of values for boiler temperature set point is OFF, 65 - 80 °C.

It is also possible to set boiler temperature set point browsing through the "User Menu" by pressing **MENU** button. When parameter "Boiler set point temperature" is displayed, the boiler temperature set point is set by pressing "+" and "-" buttons.

When the "OTC operating mode" is activated by means of **P.10** parameter of "Technical Menu" and the K-factor is set for the heating circuit of the boiler heating Zone 1 (parameter **P.45** of the "Technical" menu), the boiler temperature set point is calculated depending on the K-factor selected. The boiler temperature set point parameter only allows to set between activating ("ON") or deactivating ("OFF") the heating service of said Zone.

It is possible to disable the heating service of the boiler (**Summer** mode) by setting to "OFF" the boiler temperature set point by pressing "-" symbol for heating (**18**).

5.4 DHW SET temperature selection

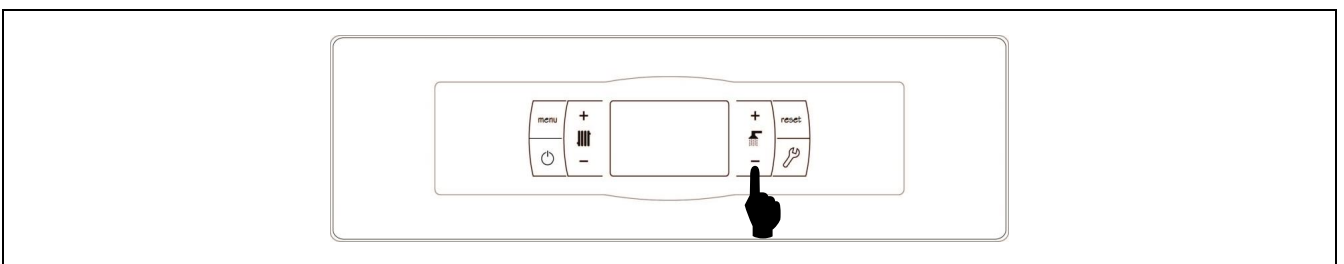

DHW SET temperature selection is made through the touch button shown in the picture. In order to select the desired operation mode touch "+" or "-" symbols to surf through the different modes. Once the mode is selected, in few seconds the screen will return to the repose situation. There are three different DHW SET modes:

- OFF: DHW function disabled.
- ECO: Reduced consumption DHW set.
- PLUS: Maximum DHW production set.

5.5 Selecting the setpoint temperature of the buffer tank (only with buffer tank)

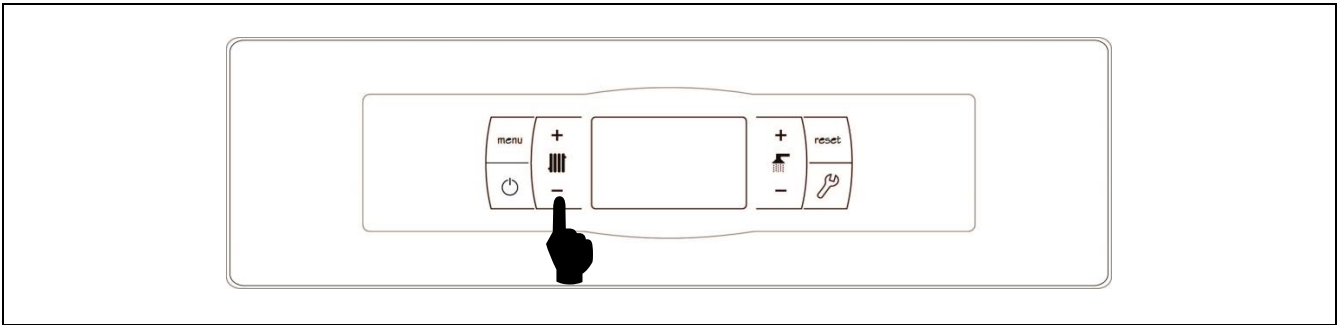

The desired buffer tank temperature is selected using the touch button, as shown in the figure. To select the desired temperature, touch the "+" or "-" symbols to increase or decrease the temperature. When the temperature has been selected, the display will return to standby mode after a few seconds. The permitted range of setpoint temperature is OFF, 30 - 80 °C.

The buffer tank setpoint temperature can also be selected by using the touch button MENU to browse to the display option "Buffer tank setpoint temperature". When this option appears on the display, touch the "+" or "-" symbols to select the desired temperature.

If you wish to totally disable the central heating function of the installation (Summer mode), select the setpoint value "OFF", by touching the "-" symbol until this value appears on the display.

5.6 Functioning according to Outdoor Temperature Conditions OTC (option)

When the boiler has the value of the outside temperature, either taken by the sensor supplied with a **BIO hydraulic kit** or taken from the Internet (by registering the boiler in the **iConnect** application), the operation can be activated according to the outside temperature (**OTC** using the **P.10** parameter of the "Technical Menu").

When this operation mode is activated, the boiler and/or heating flow temperature are automatically adjusted in accordance with the K-factor curve set at the "Technical Menu" (parameters **P.11** and **P.12** and **P.45**) and the outdoor temperature measured by the outdoor sensor. If the installation is correctly dimensioned, the boiler temperature and/or flow temperature calculated will ensure the room temperature set point set at room thermostat or remote control (if there is any connected).

The K-factor curve relates the outdoor temperature, measured by the sensor installed outside the building, with the boiler temperature set point. The diagram shows the temperature value for each point on the K-factor curve.

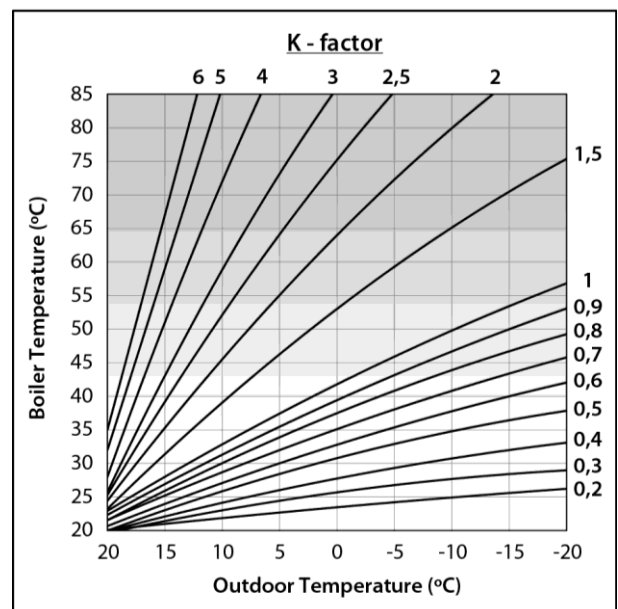

Depending on the type of heating circuit, isolation of the building and position of the outdoor sensor, the optimal K-factor curve could be different. Nevertheless, a general rule could be that for high temperature heating circuits (radiators heating circuit) the K-factor curve should be 1 or higher and for low temperature heating circuits (underfloor heating circuit) it should be 0.8 or less.

IMPORTANT: To connect the outdoor sensor AFS to BIO Hydraulic Kit, follow the connection instructions provided within the Kit.

6 OPERATING WITH BIO HYDRAULIC KITS (OPTIONAL)

All the models within **Bioclass iC DX** range of boilers may be installed together with a **BIO Hydraulic Kit** to regulate more than one heating circuit. Up to 3 heating circuits can be managed depending on the BIO Hydraulic Kit chosen. For a detailed description of the functioning of the Kit, read the manual supplied within the Kit. Nevertheless the following guidelines are given:

Direct circuit functioning

When the direct circuit pump is configured for a heating circuit (**P.23 = 0**), said circuit will work with the selected boiler temperature setpoint and the temperature of the room thermostat or sensor **TA1** or a LAGO FB OT+ remote control, both connected to the boiler terminal strips (see "Connection Diagrams"). When the boiler has an outside temperature, either read by the sensor connected to the **BIO Hydraulic Kit**, or taken from the Internet (by registering the boiler in the **iConnect** application), you can select the operation of the direct circuit according to the outside weather conditions using parameter **P.10** of the boiler's "Technical Menu", in such a way that the boiler temperature setpoint will depend on the outside temperature and the K Curve selected in parameter **P.45**.

Mixing circuit n° 1 functioning

The mixed heating circuit No. 1 will work with the setpoint of the flow temperature of the mixed circuit No. 1 selected in the "User Menu" and the temperature of the room thermostat **TaM1** or LAGO FB OT + remote control, connected in the **BIO hydraulic kit** (see "Connection Diagrams" of the Hydraulic Kit manual). (15) When the boiler has an outside temperature, either read by means of the probe connected to the **BIO Hydraulic Kit**, or obtained through the Internet (by registering the boiler in the **iConnect** application), the operation of the heating circuit no. 1 according to the outside weather conditions, using parameter **P.10** of the "Technical Menu" of the boiler, in such a way that the flow temperature setpoint of circuit no. 1 will depend on the outside temperature and the Curve K selected in parameter **P.11**.

Mixing circuit n° 2 functioning

The mixed heating circuit No. 2 will work with the setpoint of the flow temperature of the mixed circuit No. 2 selected in the "User Menu" and the temperature of the room thermostat **TaM1** or LAGO FB OT + remote control, connected in the **BIO hydraulic kit** (see "Connection Diagrams" of the Hydraulic Kit manual). When the boiler has an outside temperature, either read by means of the probe connected to the **BIO Hydraulic Kit**, or obtained through the Internet (by registering the boiler in the **iConnect** application), the operation of the heating circuit no. 2 according to the outside weather conditions, using parameter **P.10** of the "Technical Menu" of the boiler, in such a way that the flow temperature setpoint of circuit no. 2 will depend on the outside temperature and the Curve K selected in parameter **P.12**.

7 OPERATION WITH A BT BUFFER TANK (OPTIONAL)

The **Bioclass iC DX** boiler can be accompanied by a **BT Buffer tank** from the wide range of tanks offered by **DOMUSA TEKNIK**. This tank accumulates heat energy that improves the performance of the system when switching the boiler on and off. For its correct installation, carefully follow the assembly instructions included with the tank and for its correct integration with the **Bioclass iC DX** boiler, read the instructions in the section "*Installing a BT Buffer tank*" in this manual.

The electronic control of the **Bioclass iC DX** boiler is able to manage four different installation configurations of the BT buffer tank. Depending on the configuration of the installation (parameter **P.08** in the "Technician" menu) there are 2 operating modes:

7.1 Operation with a temperature sensor in the BT buffer tank (P.08 = 2)

In this operating mode you must select the desired setpoint temperature of the buffer tank (*see "Selecting the buffer tank setpoint temperature"*) and the temperature of the the room thermostat or sonde N^o. 1 (**TA₁**) or remote control **LAGO FB OT+** (if present). The burner will start working to heat the water in the boiler. When the boiler temperature exceeds 60 °C the feed pump for the buffer tank (**Bbt**) will start up to heat the BT tank. The modulating burner of the **Bioclass iC DX** boiler will keep the water in the buffer tank at the set temperature. When the temperature of the tank reaches the selected set point temperature the burner will shut down until its temperature drops to the value set in parameter **P.28** (by default 5 °C) below that desired, once again starting a new heating cycle.

Regarding the central heating service of the boiler, the circulation pump (**BC**) will be activated whenever room thermostat or sonde N^o. 1 (**TA₁**), or the remote control **LAGO FB OT+** (if present), demands heating and the temperature of the buffer tank is higher than the value set in parameter **P.50** of the "Technical" menu. In other words, when the room temperature where the thermostat or the remote control is installed is lower than that which is set. When the atmosphere reaches the desired temperature and after a time of post-circulation (parameter **P.15** in the "Technician Menu"), the operation of the heating pump (**BC**) will turn off.

The boiler's central heating service can be totally disabled (*Summer* mode) by selecting a buffer tank setpoint value of "**OFF**". In this operating mode, only the DHW production function.

NOTE: When the heating function is disabled, all the circuits of the BIO hydraulic Kit will also be disabled, if connected.

NOTE: This operating mode is only activated when parameter P.08 of the "Technician" menu is set to 2 and when there is a buffer tank installed.

7.2 Operation with a control thermostat in the BT buffer tank (P.08 = 4)

In this operating mode you must select the desired setpoint temperature of the boiler (*see "Selecting the boiler setpoint temperature"*) and, using the control thermostat installed in the buffer tank, you must also select the desired setpoint temperature in the buffer tank. **It is essential for the operation of the installation that the setpoint temperature selected for the boiler exceeds the setpoint selected for the control thermostat of the buffer tank and it is recommended that it be at least 5 to 10 °C higher.** The modulating burner of the **Bioclass iC DX** boiler will start working to heat the water within it. When the boiler temperature exceeds 60 °C the feed pump for the buffer tank (**Bbt**) will start up to heat the BT tank, provided that its control thermostat is activated (demanding heating). When the buffer tank thermostat reaches the desired temperature and turns off the heating demand, operation of the buffer tank feed pump (**Bbt**) will be disabled.

Regarding the central heating service of the boiler, the circulation pump (**BC**) will be activated whenever room thermostat or sonde N°. 1 (**TA₁**), or the remote control **LAGO FB OT+** (if present), demands heating. In other words, when the room temperature where the thermostat, sonde or the remote control is installed is lower than that which is set. When the atmosphere reaches the desired temperature and after a time of post-circulation (parameter **P.15** in the "Technician Menu"), the operation of the heating pump (**BC**) will turn off.

The boiler's central heating service can be totally disabled (**Summer** mode) by selecting a boiler setpoint value of "**OFF**". In this operating mode, only the DHW production function.

IMPORTANT: It is essential for the operation of the installation that the setpoint temperature of the boiler exceeds the setpoint selected for the control thermostat of the buffer tank.

NOTE: When the heating function is disabled, all the circuits of the BIO hydraulic Kit will also be disabled, if connected.

NOTE: This operating mode is only activated when parameter **P.08** of the "Technician" menu is set to 4 and when there is a buffer tank installed.

8 OPERATING WITH LAGO FB OT+ REMOTE CONTROL (OPTIONAL)

A remote control (**LAGO FB OT+**) can optionally be supplied together with **Bioclass iC DX** boiler. This remote control can be used to fully operate the boiler from anywhere in the room in which it is installed. The **LAGO FB OT+** remote control regulates the parameters of heating circuit.

The **LAGO FB OT+** remote control is not compatible with the boiler's **iConnect** connectivity, so if the boiler is already registered in the **iConnect** application, it will not be possible to install a **LAGO** remote control, and viceversa. If you want to install a **LAGO FB OT+** remote control, first unregister the boiler from **iConnect** using the "iCon" option in the "Configuration" menu (see "*Configuration Menu*").

This remote control allows the hours of comfort to be programmed for heating circuit, regulating the installation to the particular requirements of the building by measuring the room temperature and consequently adapting the installation temperature. The remote control can also be used to regulate the heating temperature at any time, and to display the different operating parameters of the boiler. It also warns of any malfunction affecting the boiler.

The **LAGO FB OT+** remote control may optionally be connected to an outdoor temperature sensor, for measuring the temperature around the building. With this option installed, the remote control can adjust the building comfort level according to the weather conditions, optimising fuel consumption and heating comfort in the building.

The **LAGO FB OT+** remote control takes over the control of the boiler when it is connected. The different selectable temperatures boiler of the boiler must be set at the remote control. It is easy to install, requiring only 2 wires for communication between the boiler and the **LAGO FB OT+** control, by connecting the two wires on terminal strip **J5** (see "*Electrical Connection Diagram*"). For a correct installation and functioning, read carefully the instructions within the remote control.

The following sections contain a general explanation of the different operating modes and options of **LAGO FB OT+** remote control.

Operation of the heating circuit

The maximum temperature for heating circuit, the operating period of time and the desired room temperature can be set at remote control. **LAGO FB OT+** remote control will calculate the boiler temperature required at each particular time, depending on the temperature of the room and it will activate or deactivate the heating demand depending on the heating times and room temperatures programmed.

NOTE: The installation of a LAGO FB OT+ remote control is not compatible with the iConnect system.

9 "ICONNECT" CONNECTIVITY

The **Bioclass iC DX** boiler can be connected to DOMUSA TEKNIK's "**iConnect**" connectivity platform. Through this option, the user can register the boiler in the **iConnect** application for Smartphone, Tablets or similar mobile devices, and use it to remotely manage all the user parameters of the boiler and the comfort of the heating installation, as well as receive notifications and alarms generated by the boiler, all from anywhere in the world.

9.1 Requirements for connecting to *iConnect*

The electronic control has a Wi-Fi module, through which the boiler will connect to the home's Wi-Fi network and use it to access the **iConnect** platform. As such, there must be **coverage from the home's Wi-Fi network** in the place where the boiler is installed. In turn, the Wi-Fi module built into the **Bioclass iC DX** boiler is only compatible with **2.4 GHz** frequency Wi-Fi networks.

The connection and registration in the **iConnect** application can be done with any device with an **Android 4.4** operating system or later or **iOS 13** or later (**iPhone 6S** terminal or later), and must have a **Wi-Fi** connection, **Bluetooth** connection, and enable the **location** of the boiler. To do so, it will first be necessary to download and install the free application on said device from the corresponding application platform, **Google Play** (Android) or the **App Store** (iOS).

If there is no Wi-Fi coverage at the boiler location or if it is too weak, a wide range of different repeater devices and Wi-Fi network amplifiers are available on the market. Two methods are described below to expand the coverage of the home's Wi-Fi network:

- **Wi-Fi repeater:** Consists of a device that is very easy to install, which collects the Wi-Fi signal from the home's network and replicates it, expanding the coverage area of the Wi-Fi network. To do this, the repeater must be installed in an area of the home where there is Wi-Fi coverage, which is halfway between the home Wi-Fi network router and the boiler, making sure that the range of the repeater reaches it.

This method is the most recommended due to its simplicity, ease of installation and the fact that it is cheaper than the other method, as long as the distance between the home router and the boiler is not excessive.

- **PLC devices:** Consists of a pack of 2 or more easy-to-install devices, through which the Wi-Fi router signal is transmitted through the home's electrical network. One of the devices connects to the home's Wi-Fi router and is in charge of injecting its signal into the electrical network through the outlet into which it is plugged. The other devices are plugged into the house's power outlets where the Wi-Fi coverage is to be expanded, receiving the signal through the electrical network and converting it into a Wi-Fi signal, and expanding the coverage area of the Wi-Fi network.

This method is recommended in homes or large buildings with several floors or many rooms, and when the distance between the router and the boiler is too great to be able to install a Wi-Fi repeater. Although this method is also easy to install, it is somewhat more laborious than the previous method, and since at least 2 devices are needed, it is somewhat more expensive.

9.2 Boiler registration in *iConnect*

To remotely manage the boiler through the **iConnect** APP, you must first register it in the **iConnect** connectivity platform, for which the APP must be downloaded and installed on the Smart device with which you wish to carry out the registration process. Before starting to register the boiler, we recommend activating the **Bluetooth** connection and the **location** of the device. The APP only uses the **location** function during the registration process to geographically locate the boiler and be able to update the local time and the outside temperature, so once the registration is completed, this function will not be necessary to use the application, and the location can be disabled on the device.

Once the application has been downloaded and installed, register the boiler by opening the APP and clicking on "**Register boiler**" in the home screen. Then follow the steps indicated by the APP to complete the process.

The registration consists of the following main steps:

- **Boiler connection with the Smart device:** By selecting the "**ON**" value on the "**iCon**" screen of the "Configuration" menu of the boiler's digital display, the **Bluetooth** connection will be activated and the Smart device will connect to the boiler.
- **Configuration of the home's Wi-Fi network:** The APP will ask you to enter the **Name** and **Password** of the home's Wi-Fi network and will then connect to it.
- **Entering the User registration data:** The APP will ask you to enter the User registration data, which will be used to log in to the **iConnect** application. You will also be asked to agree to the APP's "*Conditions of Use*" and "*Privacy Policy*". Once all the requested information has been filled in, the registration will be completed.
- Once the boiler registration process has been successfully completed, you will be redirected to the "Login" screen where, by entering the registered email address and password, you will access the application.

From this time on, the boiler can be accessed from any device that has the **iConnect** APP installed by logging in with the user data entered in the registration process.

This **initial registration** process will link a "**main**" user to the boiler. This **main user** will be unique, in such a way that, if a registration process is carried out again, the data of the previous user will be deleted and replaced by the new one. The main user will be able to give other users access to the APP using the "**Invite**" option in the "Configuration/Boilers" menu of the application. The "Guest" users will be able to use the **iConnect** application from any device on which it is installed and without any type of restrictions.

In turn, the same user (with the same email address and password) will be able to access several boilers from the same APP, either as the main user, performing the initial registration for several boilers, and also as a guest user, if they have received an invitation from various boilers. Through the boiler menu of the APP (right part of the APP), the user will be able to select the boiler they want to manage at all times, as well as the desired heating zone, if there is more than one installed.

9.3 Description of the *iConnect* application



All the "User" parameters of the boiler and the home heating installation can be simply and intuitively accessed through the **iConnect** App from anywhere in the world. The main functions of the **iConnect** application will be the following:

- Real-time **viewing of the status** of the boiler and the heating installation, displaying the status of the demands, ambient temperatures, boiler temperature, DHW temperature, water pressure, ash collector status, etc.
- **Selection of setpoints** for room temperature, boiler, DHW and heating circuits at any time.
- Possibility of carrying out **weekly hourly programming** of all the heating circuits and all the accessories connected to the boiler.
- Sending of **notifications and notices** from the boiler of alarm situations, warnings, maintenance notices, ash collector emptying notice, etc.
- Possibility of obtaining the outside temperature of the house from the Internet and modulating the operation of the installation according to the weather conditions (**OTC** function).
- Viewing of the fuel consumption and temperatures by means of **graphs**, and counters for the number hours of operation and consumption.
- **Selection of the language** of the Application and the possibility of contacting **DOMUSA TEKNIK Technical** Support to clarify any questions.

9.4 *iConnect* App Map

The **iConnect** Application is very intuitive and easy to use, so it is not necessary to follow an instruction manual for its use. In any case, **DOMUSA TEKNIK** provides users with a series of technical information and use tutorials on its website www.domusateknik.com/es/servicios/apps, that will help clarify any doubts. In addition, the front door or on the back cover of this manual, of the **Bioclass iC DX** has a visible QR code that can be used to directly access the **iConnect** area of the **DOMUSA TEKNIK** website..

Below, as a visual guide, is a description of the content map of the APP. The application has 3 main areas:

- **"Home" screen:** Main screen of the APP, where the status of the installation is displayed in real time and various setpoints and operating modes can be selected.
- **Main Menu:** This menu contains all the key options of the APP. Located on the left side of the APP, it can be accessed through the button  located at the top left of the "Home" screen.
- **Installations menu:** In this menu you can select the boiler and the heating zone to be displayed if there is more than one registered boiler and more than one zone installed in said boiler. Located on the right side of the APP, it can be accessed through the button  located at the top right of the "Home" screen.

"Home" screen

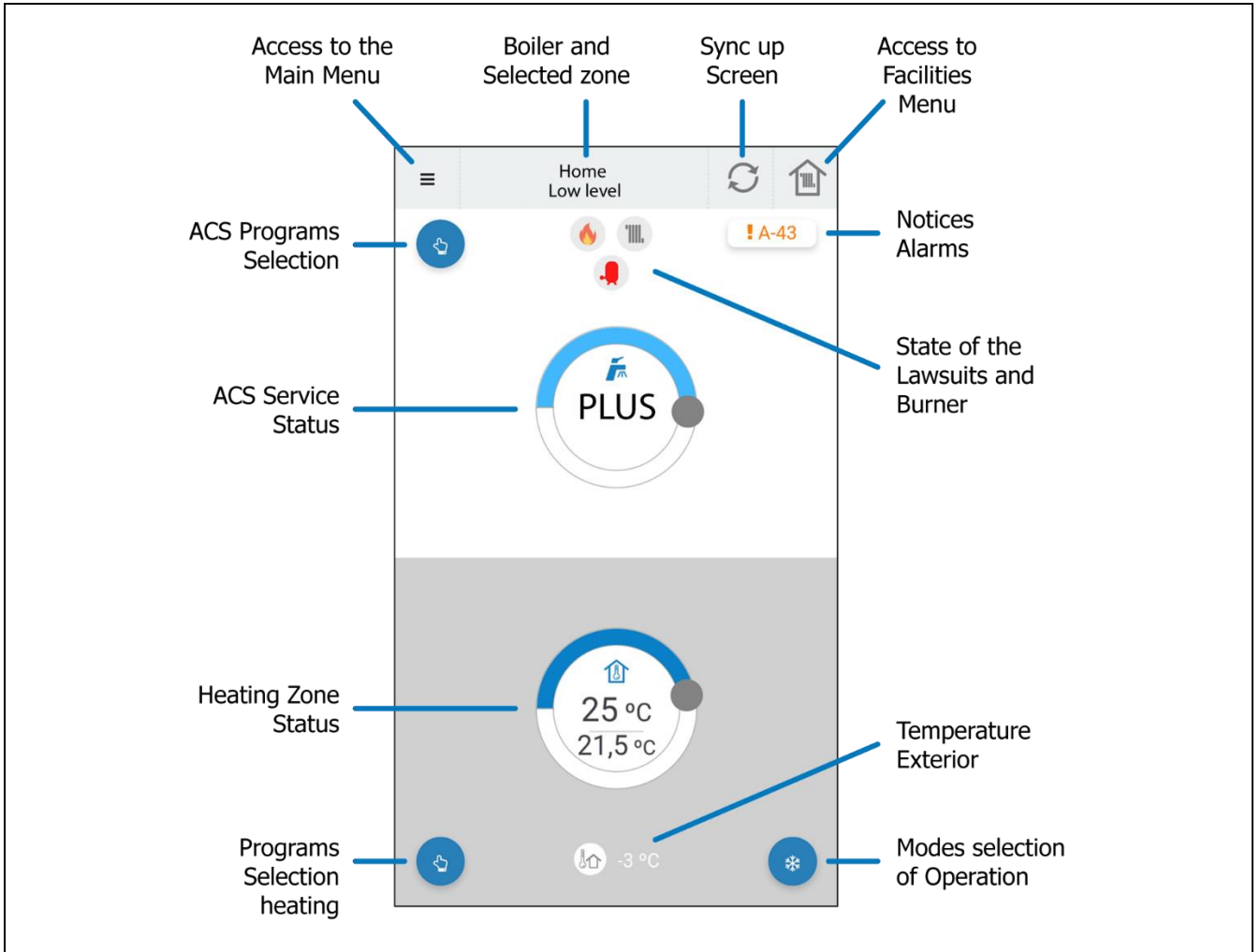

Main Menu

This can be accessed by clicking on the button  located in the upper left part of the "Home" screen, and the following options will be displayed:

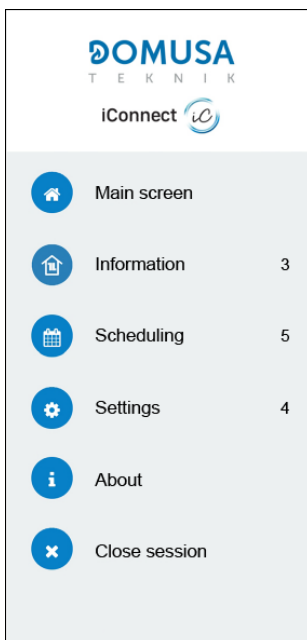



- **Main screen:** Click on this option to return to the "Home" screen.
- **Information:** This option can be used to access technical parameters related to the "Boiler" as well as the "Graphics" and "Counters".
- **Scheduling:** This option can be used to adjust all the *timer programmes* available in the boiler and to activate the "Holiday Mode" function to programme a period of days of absence from the home during which the boiler will stay turned off. The boiler will turn on automatically at the end of the set period.
- **Settings:** This option can be used to access the "General" settings of the APP, the registered "Boilers", Heating "Zones" and the user "Account" settings. It is possible to activate the **OTC** mode of the desired boiler and select the **K curve** of operation in each heating zone (*see "Operation according to external OTC climatic conditions"*).
- **About:** Use this option to access the "Terms of Use" and "Privacy Policy" and verify the version of the Application.
- **Close session:** Clicking on this option will close the user session and redirect you to the "Login" screen of the Application.

10 USER MENU

"User Menu" shows the settings related to boiler functioning on the digital display.

To access this menu press MENU; press this button repeatedly to browse through the different settings available. When one of the options is displayed, after 20 seconds the display returns to main position. In the following table are listed all the settings of "User Menu":

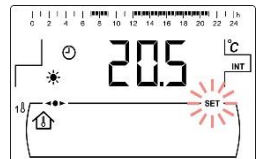
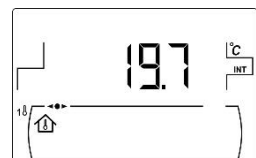
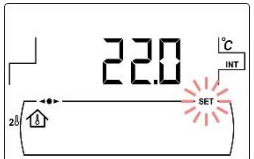
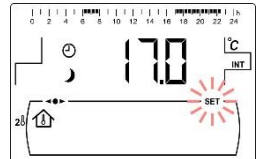
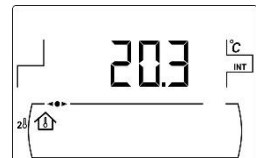
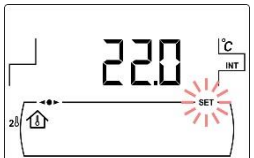
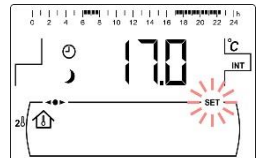
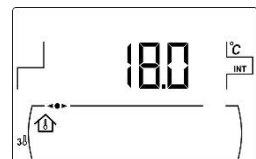
		Main position. Actual boiler temperature is displayed.
Manual mode		
Scheduled mode		Temperature setpoint of Zone 1, adjustable using the touch selector (18) . Clicking on it whilst in programmed mode will deactivate said mode and activate manual mode. <i>(only with the room sensor connected).</i>
		Real room temperature of Zone 1 <i>(only with the room sensor connected).</i>
Manual mode		
Scheduled mode		Temperature setpoint of Zone 2, adjustable using the touch selector (18) . Pressing it whilst in programmed mode will deactivate said mode and activate manual mode. <i>(Only with the Bio Hydraulic Kit and room sensor connected).</i>
		Temperatura de ambiente real de la Zona 2 <i>(Only with the Bio Hydraulic Kit and room sensor connected).</i>
Manual mode		
Scheduled mode		Temperature setpoint of Zone 3, adjustable using the touch selector (18) . Pressing it whilst in programmed mode will deactivate said mode and activate manual mode. <i>(Only with the Bio Hydraulic Kit and room sensor connected).</i>
		Real room temperature of Zone 3 <i>(Only with the Bio Hydraulic Kit and room sensor connected).</i>

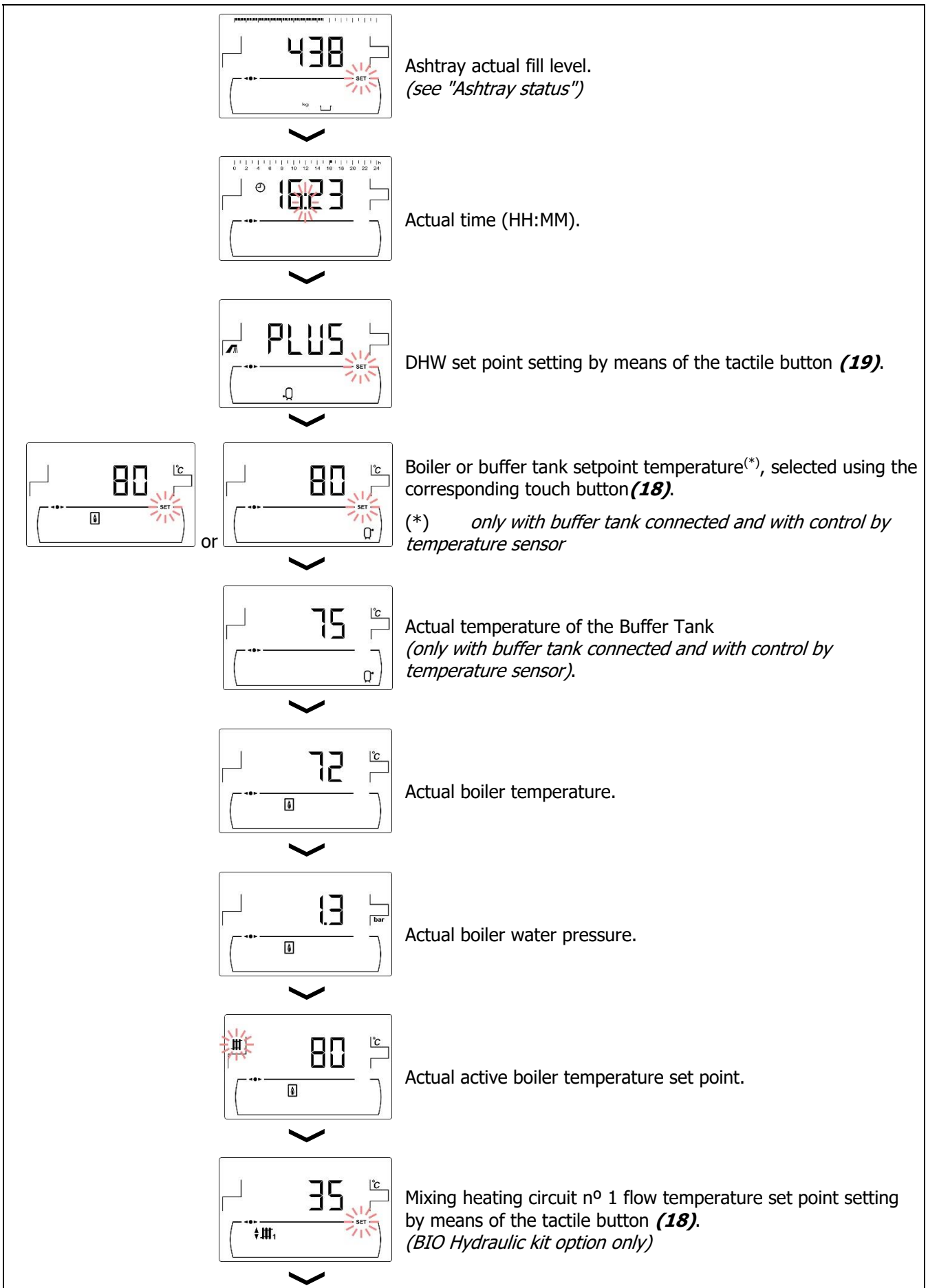

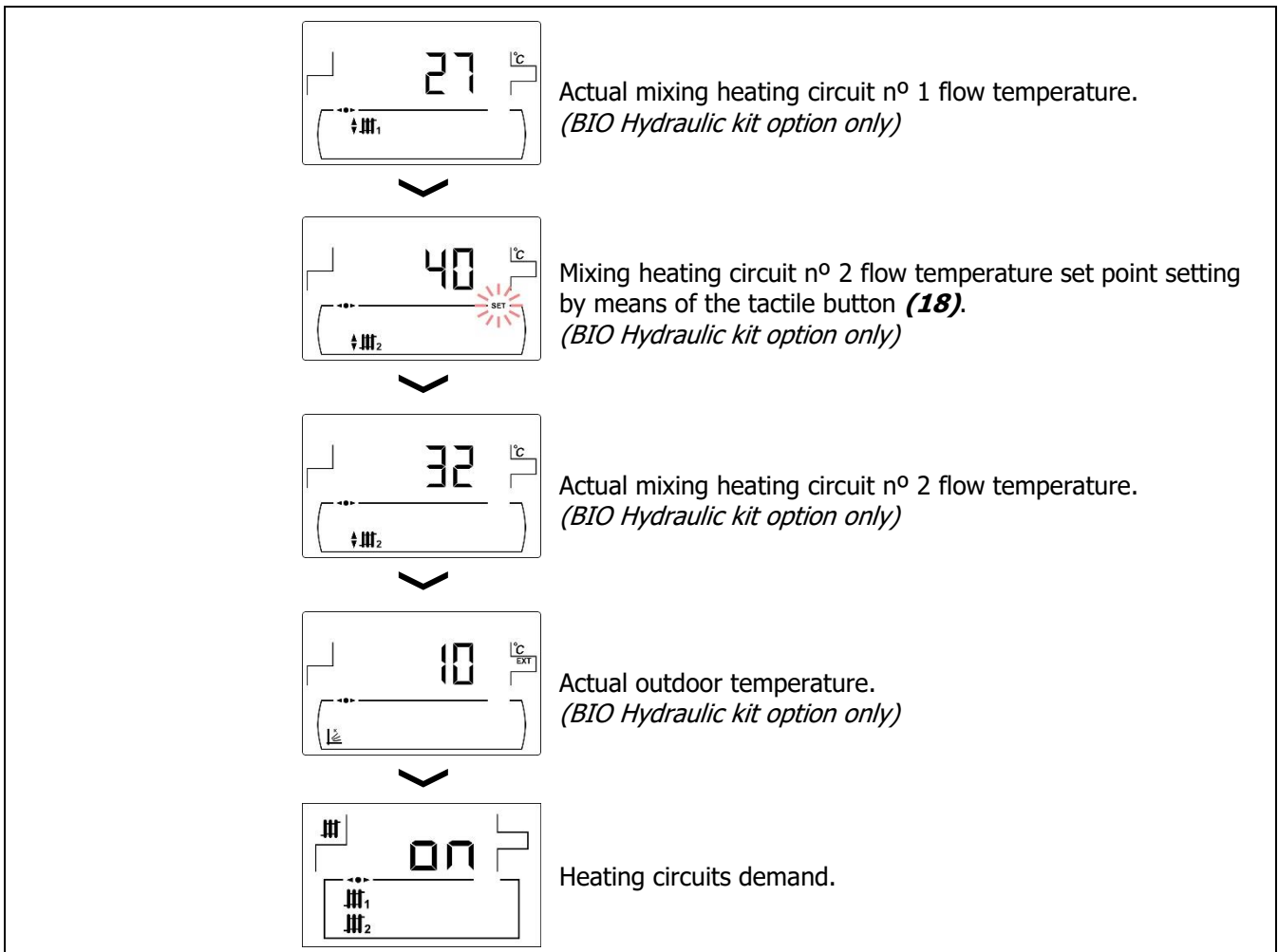

10.1 Ashtray status



When "Ashtray Empty Warning" function is activated (see "*Setup menu*"), the boiler warns about the ashtray is full and must be emptied. The parameter "*Ashtray status*" allows checking the fill level and the screen shows the ash scale bar which indicates the fill level of the ashtray. When it is full, an "*Empty the ashtray*" warning is activated. Whenever the ashtray is emptied, it is necessary to set the "*Ashtray status*" parameter to "0" by pressing "-" for DHW **(19)**.

The display of the notices is as follows:







- : Ashtray fill level between 0 and 75 %.
- flashing: Ashtray fill level between 75 and 100 %.
- and flashing: Ashtray fill level more than 100 %.

11 SETUP MENU

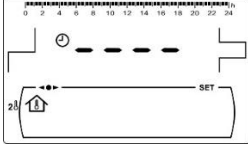
"Setup menu" consists of operating parameters of the boiler which can be adjusted by the user (Ashtray empty warning, timer programming, time setting, ...)

To access to the "**Setup menu**" press . Browse through the menu by pressing the symbols "+" or "-" of heating (18). When a parameter is displayed, press  to access and set it. When the parameter has been set, press  again, the new value will be saved and the display will return to "Setup menu". Press RESET any time to go back without recording any value.

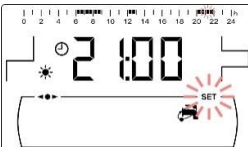
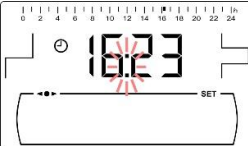
The following table lists the parameters of this menu:

Nº.	Parameter	Display
1	Time programming of Zone 1.(*) <i>(Only with the room sensor connected).</i>	
2	Time programming of Zone 2.(*) <i>(Only with the Bio Hydraulic Kit and room sensor connected).</i>	
3	Time programming of Zone 3.(*) <i>(Only with the Bio Hydraulic Kit and room sensor connected).</i>	
4	Boiler timer programming.	
5	CVS Suction System timer programming. <i>(CVS Suction System option only)</i>	
6	DHW recirculation function timer programming. <i>(DHW tank option only)</i>	
7	Time setting.	
8	Ashtray empty warning function.	
9	Manual setting of feed auger calibration.	

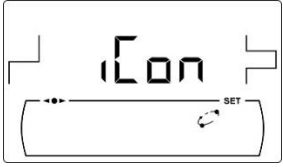
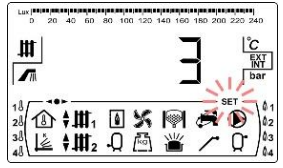
Nº.	Parameter	Display
10	Registration of the boiler in iConnect.	
11	Screen contrast setting.	

(*) When the boiler is registered in iConnect, these settings will be adjusted through the app.

IMPORTANT NOTE: It is strongly recommended that the user activate the "Ashtray emptying warning" function (see point 5 of the configuration menu and paragraph 11.6), to avoid a malfunction of the boiler due to premature fouling and a fire.

The following sections describe in detail all the parameters included in the "Configuration Menu".

11.1 Timers programming process

The **Bioclass iC DX** boiler allows you to set up to 3 different daily time schedules, time schedule for the boiler, time schedule for the automatic pellet loading system (if connected) and time schedule for the DHW recirculation pump (if this function is activated, see "Technical Menu"). By default, if no programming adjustment has been made, the boiler is supplied with the hourly programming disabled, that is, the boiler and / or the programmable function will remain active 24 hours a day (the corresponding screen will display the digits "- - -").

In turn, each of the heating zones that may have been installed in the boiler (up to a maximum of 3 zones) can have their own time programming if they have a room sensor connected. By default, the boiler comes with the heating time schedule disabled (the digits "- - - -" are displayed on the programming screen), that is, the user will manually adjust the desired temperature setpoint at each moment of the day using the corresponding screen of the "User" menu.

The adjustment process, described below, will be the same for any of the time schedules mentioned above. Once the time programming to be adjusted has been selected by pressing , it is accessed and SET will light up flashing, starting the adjustment process.

If a heating time schedule is selected, first go to the settings screens of the room temperature setpoints applied during the scheduled periods of "Comfort" temperature (☀️) and the periods of "Reduced" temperature (🌙). Touch the "+" or "-" heating symbols (18) to select this temperature:

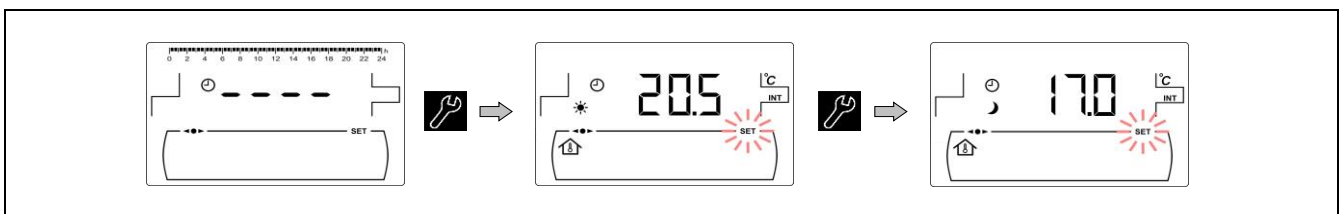

For the other time programmings, directly access the process for setting the activation and deactivation time periods for the selected function:

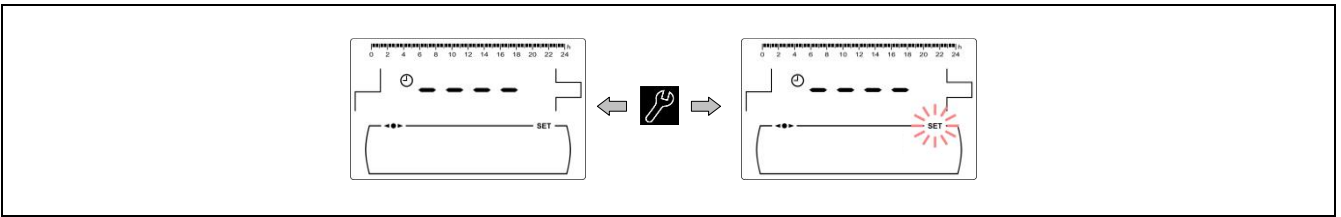

Select the time periods (30 minutes periods) by pressing "+" o "-" of heating **(18)**.

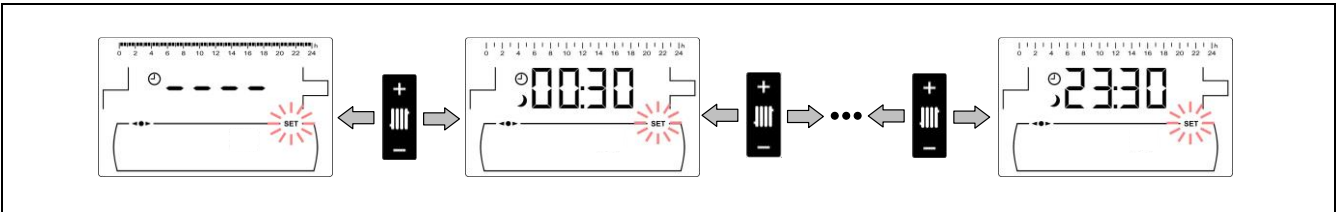

When the period desired is selected, change it state by pressing "+" o "-" of DHW **(19)**. The function will be switched off if symbol ☾ is displayed and it will be switched on if symbol ☀ is displayed.

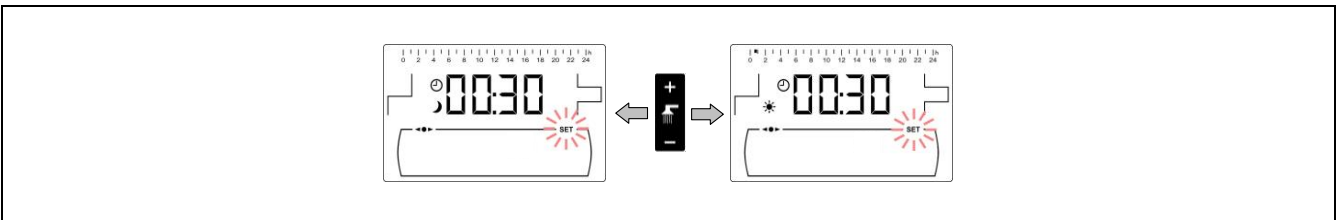

After setting all the periods desired, press to save and return to "Setup menu" level.

11.2 Heating time schedules

These schedules are only displayed for the zones if there is a room sensor connected in the corresponding heating circuit. Use this process to adjust the "Comfort" and "Reduced" heating periods you want for each heating zone installed in the boiler (). To deactivate the time programming for a zone, go to the operating periods selection screen and hold the "-" Heating symbol **(18)** until you see "----". In this way, the user can manually set the desired temperature setpoints for any time during the day.

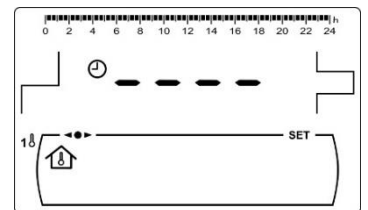

11.3 Boiler timer programming

This timer is used to adjust the switching on and off periods of the boiler functioning. To disable the timer, select boiler timer programming () and set it to "----" by pressing "-" of the boiler temperature touch button **(18)**. The boiler timer will be cancelled and it will be switched on permanently.

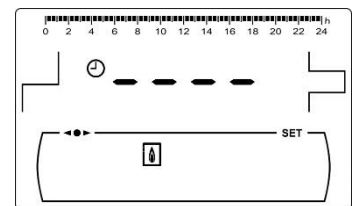

11.4 CVS Suction System timer programming (CVS Suction System option only)

This timer is only displayed when an **CVS Suction System** is connected to the boiler. It is used to adjust the switching on and off periods of the **CVS Suction System** functioning. To disable the timer, select the **CVS Suction System** timer programming (🕒) and set it to "-- --" by pressing "-" of the boiler temperature touch button **(18)**. Kit timer will be cancelled and it will be switched on permanently.

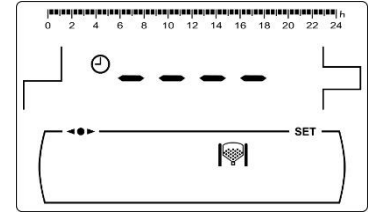

11.5 DHW recirculation function timer programming (DHW tank option only)

This timer is only displayed when the DHW recirculation function is selected in the multifunction relay parameter (**P.20 = 2**) of the *Technical Menu*. It is used to adjust the switching on and off periods of DHW recirculation pump. To disable the timer, select the DHW recirculation timer programming (🕒) and set it to "-- --" by pressing "-" of the boiler temperature touch button **(18)**. The timer will be cancelled and DHW recirculation pump will be switched on permanently.

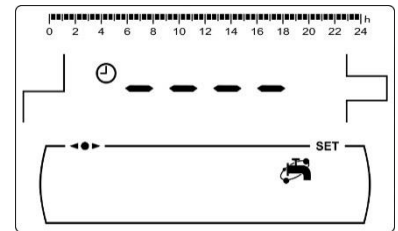

11.6 Time setting

When *"Time setting"* parameter of *"Setup menu"* is displayed, press 🔧 to access. The first two digits of numerical digits blinks (hours) and setting process begins:

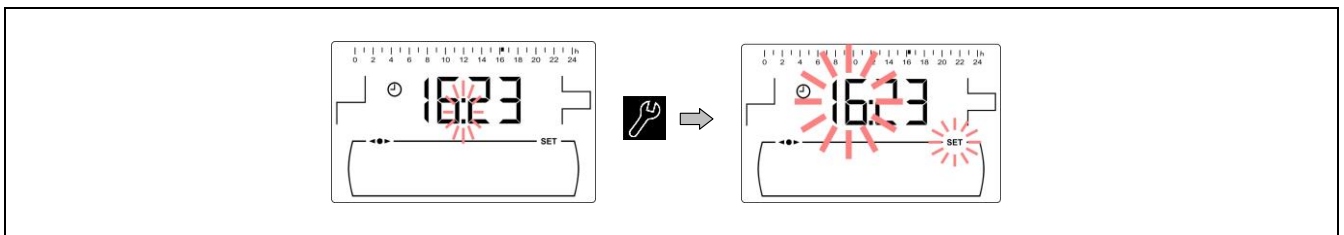

Set the hour value by pressing "+" or "-" of DHW **(19)**. Pressing 🔧 the value is saved and the minutes digits blinks to set them.

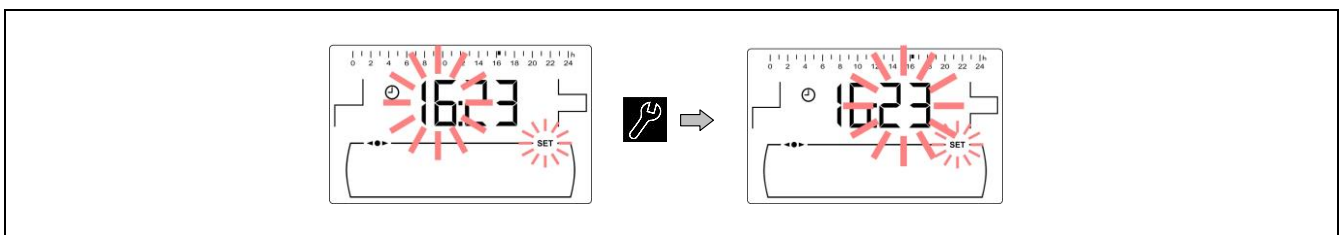

Set the minutes value by pressing "+" or "-" of DHW **(19)**. Pressing 🔧 the value is saved and it returns to *"Setup menu"* level.

When the boiler is registered in **iConnect**, it will not be necessary to set the time as it will be automatically set and synchronised by the APP, so this screen from the *"Configuration"* menu will not be displayed.

11.7 Ashtray empty warning function

With this function activated, the boiler will notify when the boiler ashtray is full and needs emptying. The "Ashtray status" parameter of the "User Menu" shows the status of the ashtray at any given time. When it is full, a warning will be activated (**E-43**), indicating that it needs to be emptied. By default, the boiler comes with the ashtray reminder function activated and set to indicative fuel consumption values, according to the **Bioclass iC DX** boiler model which, depending on the quality and type of fuel, will have to be adjusted for each system.

Select "Ashtray empty warning" (🔥) parameter of "Setup menu" and press 🔧 to access. The value is set by pressing "+" and "-" symbols of DHW (**19**). It is possible to deactivate this function by setting the value of this parameter to "OFF".



The following table shows the kilogrammes of consumption at which the boiler will issue a reminder to empty the ashtray:

Model	Fuel Kg
Bioclass iC DX 18	750 kg
Bioclass iC DX 25	1000 kg

NOTE Every time a value of this parameter is set, the ashtray must be emptied (see paragraph 19) (See "Ashtray cleaning").

11.8 Manual setting of feed auger calibration

When this parameter is displayed (🔧) on "Setup menu", press 🔧 to access and set the value desired by pressing "+" or "-" of DHW (**19**). The range of values selectable is OFF, 0.500 - 5.000 kg.

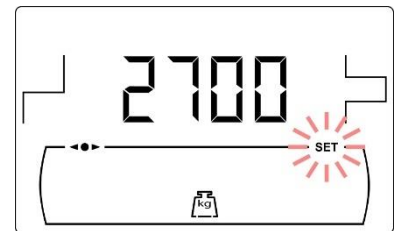

11.9 Registration of the boiler in iConnect

Use this option to activate the boiler registration process in the **iConnect** APP. First download and install the application on a mobile device, tablet, or similar, and go to the "Register boiler" option of the home screen. Use the **iConnect** APP to remotely access all the home comfort management parameters from anywhere in the world (see "iConnect connectivity").

Once you have selected the "iCon" screen (🔄) from the "Configuration Menu", press the 🔧 symbol to access it. **SET** will flash, and use the "+" or "-" DHW symbols (**19**) to set the desired value. To activate the registration of the boiler in **iConnect** set the value to "ON". Once you have completed the registration process in the APP, the value "REG" will be displayed, indicating that the registration was successful. Setting this value of the screen to "OFF" will disconnect the boiler from **iConnect**, unregistering the APP.

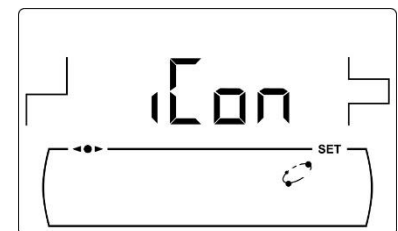



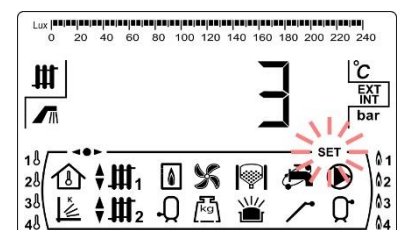

11.10 Screen contrast setting



When this parameter of the "Setup menu" is displayed, press 🔧 to access and set the value desired by pressing "+" or "-" of DHW (**19**). The range of values selectable is 1 - 5.



12 CALIBRATION MENU

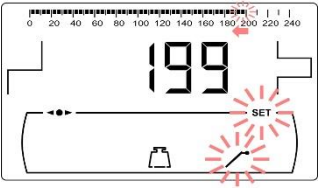

"*Calibration Menu*" consists of a number of processes and parameters that allow the correct set up of the boiler.

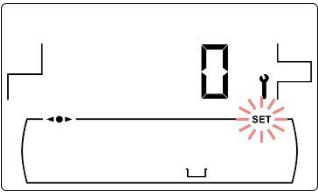
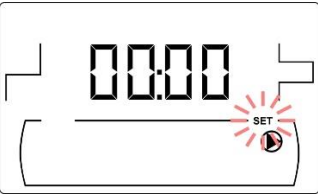
To access the "**Calibration Menu**", the boiler must be switched off by pressing  tactile button. After having switched off the boiler press  for 5 seconds to access to the menu. Browse through the menu by pressing the symbols "+" or "-" of heating **(18)**. When the desired parameter is displayed, press  to access and set it. When the parameter or process has been set, press  again, the value will be saved and the display will return to "*Calibration menu*". Press RESET any time to go back without recording any value. In the following table are listed all the parameters and processes included in "*Calibration menu*":

Nº.	Parameter	Display
1	Feed auger filling	
2	Feed auger calibration	
3	Manual setting of feed auger calibration	
4	Manual ash cleaning activation	
5	Manual circulation pumps activation	

12.1 Feed auger filling

During the commissioning of the boiler, before calibrating the feed auger or if the hopper runs out of fuel, **it is compulsory** to fill of fuel the feed auger. By means of this parameter the feed auger will be filled of fuel, process required for a correct boiler functioning.

When "Feed auger filling" parameter is displayed (✓) on "Calibration Menu", press  to access. SET symbol blinks and pressing  again it will be activated filling procedure. The feed auger will be activated and a count up to 15 minutes (maximum) will be displayed. During the process by pressing  the feed auger could be stopped at any time and by pressing RESET the filling procedure could be finished and return to "Calibration Menu" at any time.

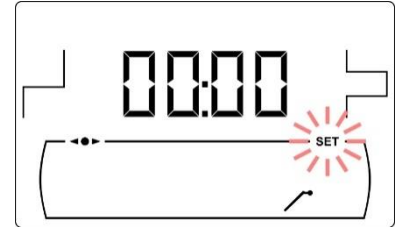

To ensure a complete filling of boiler feed auger it is recommended to make a complete 15 minute procedure of filling, at least once. Follow the steps shown in the following pictures for a correct filling of the feed auger:

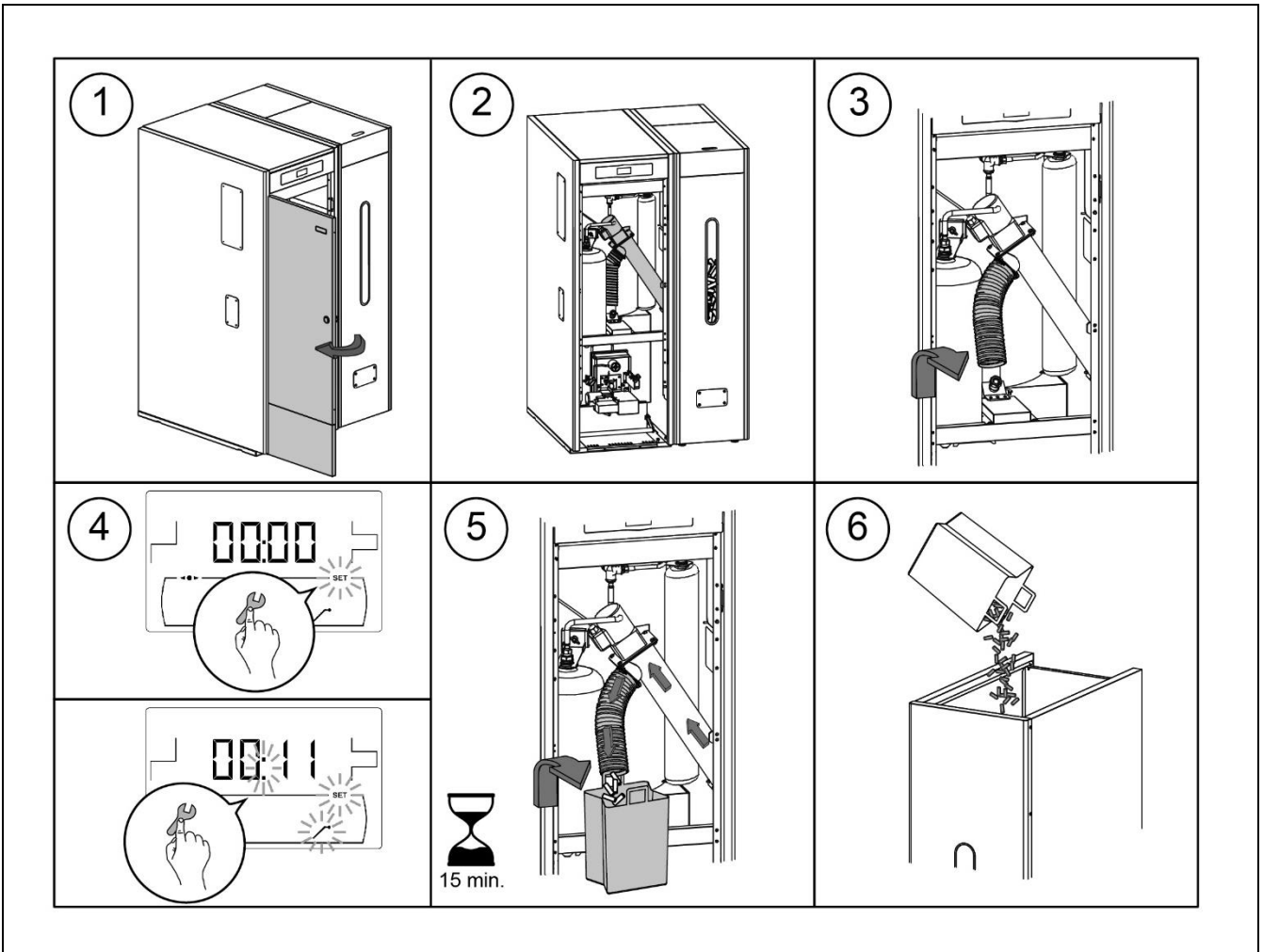

IMPORTANT: It is compulsory to fill the feed auger during the commissioning or when the hopper runs out of fuel.

12.2 Feed auger calibration

By means of calibrating the feed auger the electronic controller of the boiler adjusts the optimum amount of fuel required to supply the burner and to produce the correct heat output and combustion. By means of this parameter the feed auger calibration procedure will be made, process required for a correct boiler functioning. **In any case the hopper is empty or it runs out of fuel, it is compulsory to fill the feed auger before carrying out the calibration process.**

When "Feed auger calibration" parameter is displayed (🔧) on "Calibration Menu", press 🔧 to access. SET symbol blinks and pressing 🔧 again it will be activated calibration procedure. The feed auger will be activated and a countdown from 200 doses will begin. When the countdown finishes current calibration value will be displayed, press 🔧 to adjust the new value obtained during the procedure by pressing "+" or "-" symbols of DHW (19). Finally pressing 🔧 the value will be saved and it will return to Calibration Menu level.

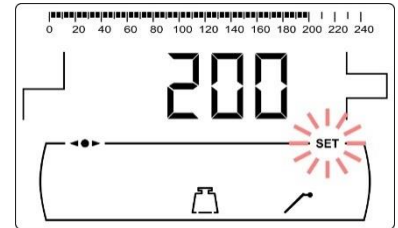

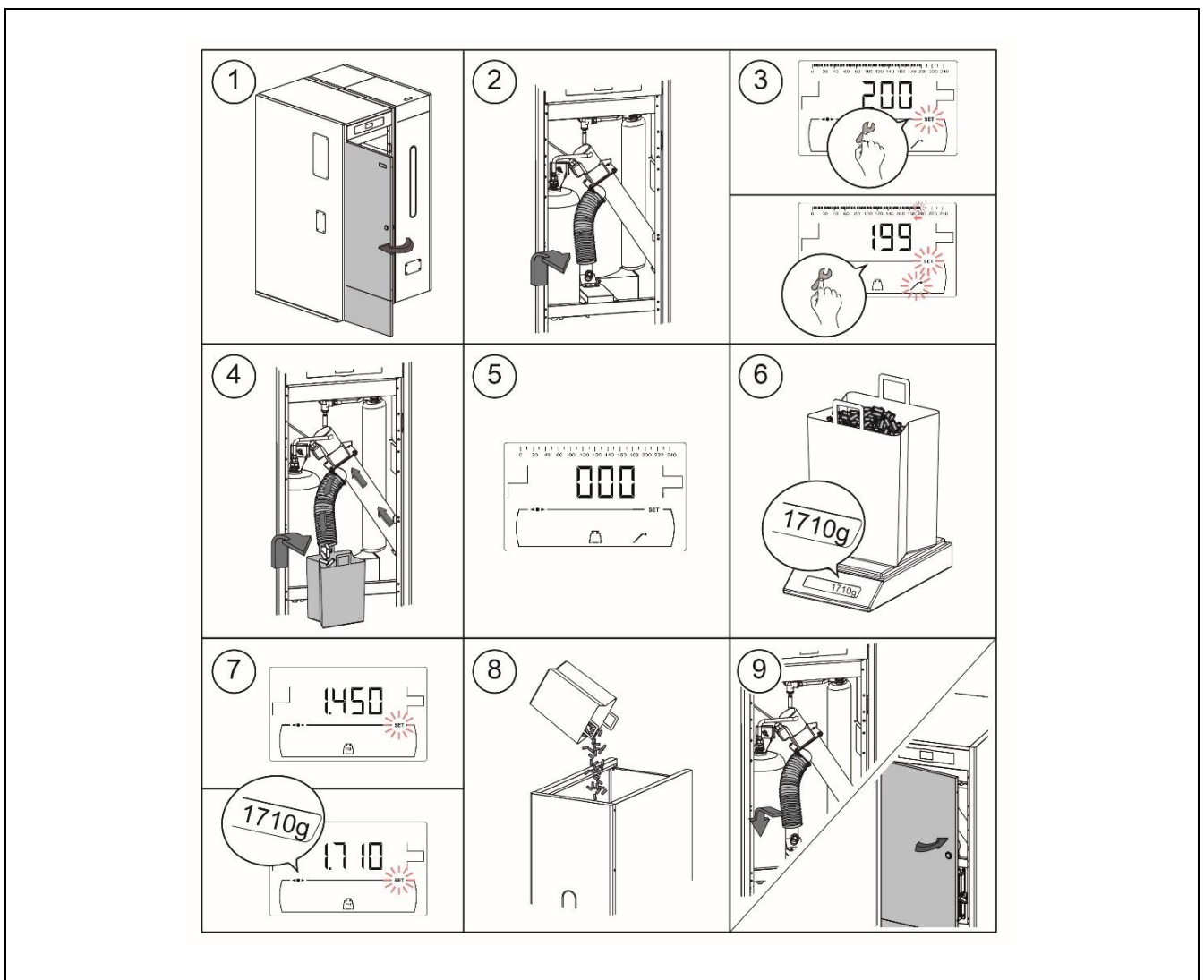

This process must be carried out at least twice to ensure the correct amount of fuel has been added. Follow the steps shown in the following pictures for a correct calibration of the feed auger:





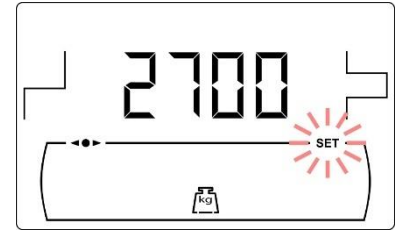

IMPORTANT: Calibrate the feed auger during commissioning of the boiler or whenever the fuel supplier has been changed.

12.3 Manual setting of feed auger calibration

By means of this parameter the weight obtained in the feed auger calibration procedure can be set manually. When "Manual setting of feed auger calibration" parameter is displayed () on "Calibration Menu", press  to access and set the value desired by pressing "+" or "-" of DHW (19). The range of values selectable is OFF, 0.500 - 5.000 g.



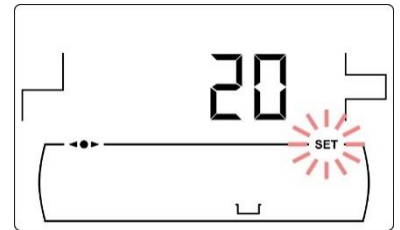

12.4 Manual ash cleaning activation

By means of this parameter the burner ash cleaning device can be switched on manually up to a maximum of 20 cleaning cycles. When "Manual ash cleaning activation" parameter is displayed () on "Calibration Menu", press  to access. SET symbol blinks and pressing  again it will be activated the cleaning system. A countdown of 20 cycles will be displayed. When the countdown is finished the cleaning device will stop. By pressing  the cleaning procedure can be stopped at any time and by pressing RESET it will return to "Calibration Menu" level.



12.5 Manual circulation pumps activation

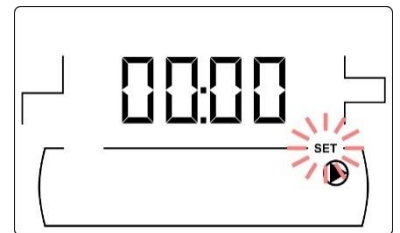

By means of this parameter the circulation pumps can be switched on manually. When "Manual circulation pump activation" parameter is displayed () on "Calibration Menu", press  to access. SET symbol blinks and pressing  again the circulation pumps will be activated for a period of not more than 20 minutes.









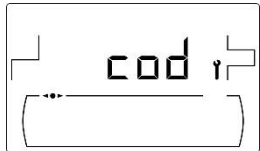
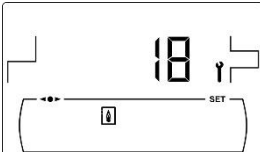
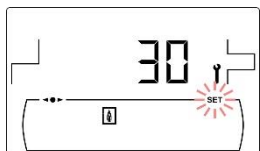
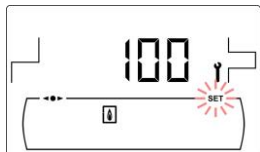
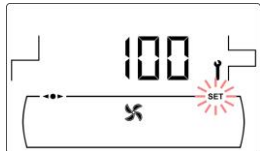
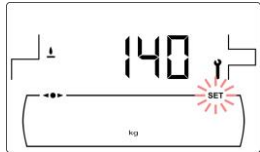

By pressing  the circulation pumps can be stopped at any time and by pressing RESET it will return to "Calibration Menu" level.



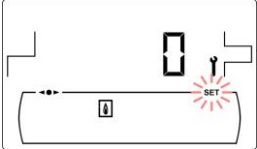
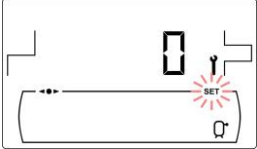



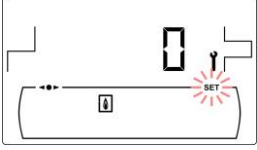

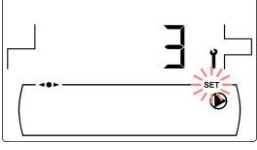
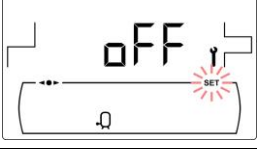
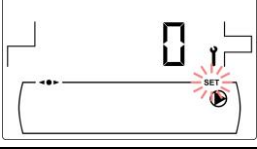
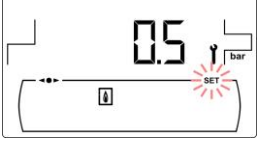
13 TECHNICAL MENU

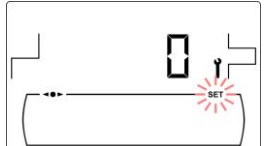
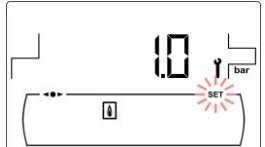



"*Technical Menu*" consists of a number of technical operating parameters that only have to be modified by a person with sufficient technical knowledge of the meaning of each parameter. Any inappropriate setting of a parameter of "*Technical Menu*" can cause a serious malfunctioning of the boiler and could cause damages to people, animals or things.

To access the "*Technical Menu*" press MENU and RESET tactile buttons together for 5 seconds. Access code ("cod") request will be displayed (see "*Entry and set the access code*"). After entering the correct code, the first parameter of "*Technical menu*" will be displayed. Browse through the menu (**P.01**, ..., **P.53**) by pressing the symbols "+" or "-" of heating (**18**). When the desired parameter is displayed, press  to access and set it by pressing the symbols "+" or "-" of DHW (**19**). When the parameter has been set, press  again, the value will be saved and the display will return to "*Technical menu*". Press RESET any time to go back without recording any value. The following table lists these parameters and they are described in detail in the following sections of the manual:

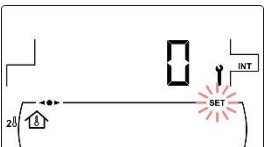
N°	Parameter	Display
Cod	Access code (by default 1234)	
P.01	Boiler model	
P.02	Minimum boiler heat output (%)	
P.03	Maximum boiler heat output (%)	
P.04	General fan speed factor (%) (Visible only with C.01 = 0 or C.01 = 1)	
P.05	Fuel for ignition (g)	
P.06	Fuel consumption (kg/h)	

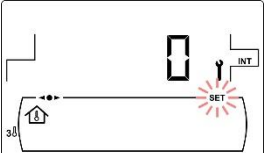
N°	Parameter	Display
P.07	Fuel type	
P.08	Selecting the type of installation for the BT buffer tank <i>(Only with buffer tank installed)</i>	
P.10	OTC function according to outside conditions <i>(Only with the Bio Hydraulic Kit option or boiler registered in iConnect)</i>	
P.11	K curve of mixed circuit no. 1 (Zone 2) <i>(Only with Bio Hydraulic Kit option)</i>	
P.12	K curve of mixed circuit no. 2 (Zone 3) <i>(Only with Bio Hydraulic Kit option)</i>	
P.13	Boiler minimum temperature mode	
P.14	Minimum boiler temperature (°C)	
P.15	Heating pump post-circulation time (min)	
P.17	Legionella protection function <i>(DHW tank option only)</i>	
P.18	Boiler's pump operating mode (BC)	
P.19	Minimum boiler water pressure (bar)	

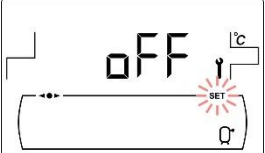
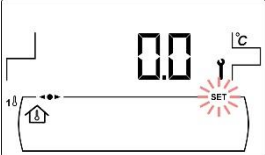
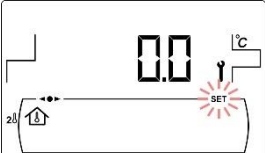
N°	Parameter	Display
P.20	Multifunction relay	
P.21	Automatic water filling pressure(bar) <i>(P.20 = 3 option only)</i>	
P.22	CVS Suction System cycle time (s) <i>(CVS Suction System option only)</i>	
P.24	Reset default values	
P.25	Set access code	
P.26	Auxiliary parameter for fuel selection	
P.27	Maximum heating flow temperature of mixed circuits <i>(Only with the optional Hydraulic Kit Bio)</i>	
P.28	BT buffer tank temperature hysteresis <i>(Only with buffer tank installed)</i>	
P.45	K curve of the direct circuit (Zone 1)	
P.46	Type of room temperature device in Zone 1 (Direct circuit)	
P.47	Type of room temperature device in Zone 2 (Mixed circuit 1) <i>(Only with Bio Hydraulic Kit option)</i>	

N°	Parameter	Display
P.48	Type of room temperature device in Zone 3 (Mixed circuit 2) <i>(Only with Bio Hydraulic Kit option)</i>	
P.49	Room temperature hysteresis (Only with connected room sensor)	
P.50	Minimum temperature for BT tank heating (Only with buffer tank installed)	
P.51	Zone 1 room temperature correction	
P.52	Zone 2 room temperature correction <i>(Only with Bio Hydraulic Kit option)</i>	
P.53	Zone 3 room temperature correction <i>(Only with Bio Hydraulic Kit option)</i>	

13.1 Entry and set the access code ("cod", P.25)

When the access code request is displayed or to set a new one (**P.25**), press  to access. **SET** symbol blinks and it would be possible to enter the code or set it. Press the "+" o "-" for heating symbols (**18**) to browse trough the digits and press the "+" o "-" for DHW symbols (**19**) to set each digit. By default, the access code is "1234". The **P.25** parameter allows to set a new access code.

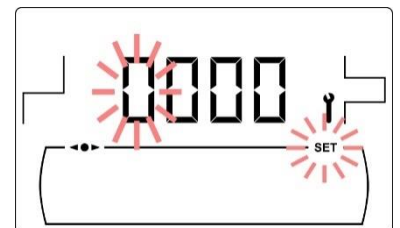

14 BOILER'S SETUP PARAMETERS

The following parameters in the "*Technical Menu*" allow to adjust the boiler to each installation. They only may be modified by a person with sufficient technical knowledge of the meaning of each parameter. Any inappropriate setting of a parameter of "*Technical Menu*" can cause a serious malfunctioning of the boiler and could cause damages to people, animals or things.

14.1 Boiler Model (P.01)

Parameter **P.01** displays the model of the boiler set at DIP-switch on the electronic board.

P.01 = 18 => Bioclass iC DX 18

P.01 = 25 => Bioclass iC DX 25

14.2 Boiler heat output (P.02, P.03)

Bioclass iC DX boiler is configured to modulate between a minimum and a maximum burner heat output. By means of parameters **P.02** and **P.03** the minimum and maximum heat output of the burner may be set at desired value. The range of modulation selectable depends on the model of boiler and the type of fuel set.

14.3 General fan speed factor (P.04)

Using parameter **P.04**, a multiplication factor for the fan speed percentage can be set when automatic fan adjustment is not activated. Using this parameter, the amount of combustion air can be increased or decreased, to ensure correct combustion values. Changing its value modifies the percentage of the fan throughout its modulation curve. The selectable range of parameter **P.04** is 0 - 200 (by default 100), if a value lower than 100 is set, the amount of air will be decreased and if a value higher than 100 is set, it will be increased.

14.4 Fuel for ignition (P.05)

By means of parameter **P.05** the amount of fuel for burner ignition procedure may be set at desired value. The default value depends on the model of boiler and the type of fuel set. The range of values selectable is 0 - 900 g.

14.5 Fuel consumption (P.06)

By means of parameter **P.06** the amount of fuel consumed by the boiler at 100% heat output may be set, in kilograms per hour. This parameter is related to the boiler model (heat output) and the type of fuel used, as well as its calorific value. The range of values selectable is 1.00 - 30.00 kg/h.

14.6 Fuel type (P.07)

By default **Bioclass iC DX** boiler is configured to burn wood pellets. By means of parameter **P.07** another type of fuel may be selected:

P.07 = 0 => Wood pellet.

P.07 = 1 => Olive stone.

14.7 Managing BT buffer tanks (P.08, P.28, P.50)

Parameter **P.08** is used to set the type of hydraulic installation that has been used for the **BT** buffer tank. This parameter depends on the installation and must be set by the installer once the buffer tank has been assembled. The factory default value is 0, management function of BT buffer tanks disabled. The electronic control of the **Bioclass iC DX** boiler is able to manage the operation of 2 different types of installation.

P.08 = 0 => Function disabled (default value).

P.08 = 2 => Installation with Sanit DHW tank before BT tank and control by temperature sensor.

P.08 = 4 => Installation with Sanit DHW tank before BT tank and control by thermostat.

When the installation type **2** is selected, by means of parameter **P.28**, it is possible to adjust the hysteresis of temperature for the sensor **Sbt**, in order to set the temperature to start up and stop the BT buffer tank heating operation. The parameter **P.28** can be adjusted between 5 and 40 °C and by default it is set to 5 °C. In turn, parameter **P.50** can be used to set a minimum temperature at which the operation of the heating circuits connected to the buffer tank will be activated. Below this temperature, the heating circuits will remain deactivated. The selectable range of parameter **P.50** is OFF, 30 - 70°C and the factory default value is OFF.

14.8 Auxiliary parameter for fuel selection (P.26)

By means of parameter **P.26** the combustion may be set to the fuel characteristics. This parameter is related to the boiler model (heat output) and the type of fuel used. The range of values selectable is 0.000 - 99.99 kg/h and the default value depends on the model of boiler and the type of fuel set:

14.9 Boiler minimum temperature mode (P.13, P.14)

By means of parameters **P.13** and **P.14** a different mode of temperature managing may be set (by default **P.13 = 0**), if heating or/and DHW services are enabled. When parameter **P.13** is set to 0, by parameter **P.14** the minimum temperature can be selected as desired, between 30 and 60 °C. The following regulation modes of minimum temperature can be selected:

P.13 = 0 => Maintains the minimum temperature set at **P.14** parameter (by default).

P.13 = 1 => Maintains the boiler temperature set point.

P.13 = 2 => Does not maintain any boiler temperature.

15 HEATING CIRCUIT'S SETUP PARAMETERS

The **Bioclass iC DX** boiler is equipped with an electronic control capable of regulating the automatic operation of the boiler efficiently and also incorporates the following functions to control the heating circuits integrated in it:

15.1 Heating pump post-circulation time (P.15)

This function keeps the heating pump (**BC**) running for a period of time after deactivating the heating service, to avoid the overheating due to the temperature inertias of the heating installation. By means of parameter **P.15** the period of time that the pump continues to operate may be set. The range of values selectable is 0 - 40 minutes (by default 3 minutes).

15.2 Boiler's pump operating mode (P.18)

The electronic controller allows to select between two operating modes of boiler's circulating pump (**BC**) by means of **P.18** parameter of the "Technical Menu". The following operating modes can be selected:

P.18 = 0 => Standard mode: The circulation pump will be run depending if the heating demand is activated or not.

P.18 = 1 => Continuous mode: The pump continues to run provided that the heating mode is enabled (boiler temperature set point different to OFF). If there is room thermostat or remote control connected to the boiler, the electronic controller will regulate the burner functioning according to the heating demand, keeping the pump running continuously.

15.3 Minimum boiler water pressure (P.19)

Bioclass iC DX is equipped with a water pressure sensor that makes possible to know the pressure of the boiler. If the pressure descends below the value set at **P.19** parameter, the electronic controller locks out the functioning of the boiler and **E-19** alarm code is displayed (see "Safety lock-outs"). The range of values selectable is 0.1 - 0.5 bar (by default 0.5 bar).

15.4 Maximum heating flow temperature of mixed circuits (P.27)

The electronic controller allows to select the maximum heating flow temperature for mixed circuits installed in the boiler with an optional Bio Hydraulic Kit. By means of parameter **P.27** the maximum heating flow temperature may be set. The range of values selectable is 45 - 80 °C (by default 45 °C for mixed circuits)).

15.5 Type of room temperature device (P.46, P.47, P.48)

The **Bioclass iC DX** boiler is capable of managing the temperature conditions inside the home for each heating zone connected to it by means of 2 types of devices (see "Installing a room sensor or thermostat"). Use parameters **P.46** (Zone 1), **P.47** (Zone 2) and **P.48** (Zone 3) to set the type of room temperature device installed in each heating area.

P.46, P.47 or P.48 = 0 => Room thermostat.

P.46, P.47 or P.48 = 1 => Room sensor.

15.6 Room temperature hysteresis (P.49)

Parameter **P.49** can be used to adjust the hysteresis of the room temperature required to reactivate the demand, i.e. once the desired room temperature has been reached in the room, how much it will have to fall below that temperature for the heating demand to be reactivated. The appropriate choice of the value of this parameter will avoid excessive cycling of the activation of the heating demand of the boiler, optimising its operation. The optimal value will depend on the level of the home's thermal insulation; the higher the insulation level, the lower the value of parameter **P.49** can be. In turn, if the insulation level is reduced, it is recommended to increase the parameter. This parameter will only be applied in heating zones where there is a connected room sensor. The selectable range of parameter **P.49** is 0.2 - 5°C and the factory default value is 0.5°C.

15.7 Room temperature correction (P.51, P.52, P.53)

Through these parameters it is possible to compensate the temperature measurements differences in the temperature sensors. Selectable range P.51 (zone 1), P.52 (zone 2) and P.53 (zone 3) is -5,0 - +5,0 °C and the default value is 0,0 °C.

16 DHW CIRCUIT'S SETUP PARAMETERS

The **BioClass iC DX** boiler is equipped with an electronic controller to regulate a domestic hot water production service. The following parameters are used to configure the ACS service related parameters. These parameters will only be accessible in the "Technical Menu".

16.1 Legionella protection function (P.17)

This option prevents the proliferation of legionella bacteria in the DHW tank. Every 7 days the temperature of tank hot water is increased to 70 °C to kill the bacteria. This function is only active if the boiler is turned on and a DHW tank is connected. By means of parameter **P.17** the protection against Legionella bacteria function may be activate or deactivate. By default this function is set deactivated.

16.2 DHW re-circulation function (P.20 = 2)

The multifunction of the auxiliary relay output allows to install a DHW re-circulating pump in DHW hydraulic circuit, in order to increase the comfort of DHW service. To activate this function read "*Multifunction-Relay functions*" section.

17 ADDITIONAL FUNCTIONS

The **Bioclass iC DX** boiler incorporates the following additional control functions:

17.1 CVS Suction System cycle time (P.22)

Bioclass iC DX boiler allows the installation of an optional automatic fuel loading system **named CVS Suction System**. By means of parameter **P.22** the activation cycle time of the loading system may be set. This parameter will be available only if an **CVS Suction System** is connected to the boiler. The range of values selectable is 35 - 195 seconds (by default 195 s). For a detailed information follow the instructions included within the **CVS Suction System**.

17.2 Reset default values (P.24)

In case any parameter is wrongly set or if the boiler works incorrectly, all the original values of the parameters can be reset automatically by selecting "Yes" in **P.24** parameter.

17.3 Pumps anti-lock function

This function prevents the boiler circulating pumps from locking if they have been out of use for a long period of time. This system remains enabled while the boiler is plugged into the mains.

17.4 Anti-frost function

This function protects the boiler from freezing during cold weather periods. If the boiler temperature drops below 6 °C, the heating pump will start running until the boiler temperature reaches 8 °C. If the boiler temperature continues to drop below 4 °C, the burner will start running, in order to heat the installation. It will continue working until the boiler reaches 15 °C. This system remains on standby while the boiler is plugged into the mains.

17.5 Boiler pressure sensor function

This function prevents boiler failure caused by a low or high water pressure level in the boiler. The pressure is detected by a pressure sensor and its value appears on the control panel display (in the "User Menu"). When the pressure drops below the pressure set at **P.19** parameter (by default 0.5 bar), the electronic controller locks out the boiler functioning and displays **E-19** alarm code on the screen. When the boiler pressure exceeds 2.5 bar, **HI** alarm code is displayed on the screen, warning about the excess of pressure. When it occurs repeatedly it is recommended calling the nearest **Technical Assistance Service** and draining the boiler water until the pressure is between 1 and 1.5 bar.

17.6 Connecting the LAGO FB OT+ remote control

The boiler has the terminal strip **J5** for connecting the **LAGO FB OT+** remote control (see "Connection Diagram") which will allow managing the heating service of the boiler depending on the temperature of the house.

Installing a **LAGO FB OT+** remote control enables the heating services to adapt to the scheduled times of use of the installation. It also optimises the installation's functioning, adapting the heating temperature set point to the room temperature, improving the comfort.

17.7 Room thermostat connection

The boiler has a terminal strip **J6** for connecting a room thermostat or a room chrono-thermostat (**TA₁**, see "*Connection Diagram*") that allows to switch on and off the heating circuit demand according to the actual room temperature. For correct connection and configuration, carefully read the instructions in the section "Installing a room probe or thermostat".

Installing a room thermostat will optimise the installation's performance, adapting the heating to building requirements and obtaining enhanced comfort. Also, if the thermostat allows the hours of functioning to be programmed (chronothermostat), it can adapt the heating system to the hours of use of the installation.

17.8 Connecting the room sensor

The boiler has a **J6** terminal strip, prepared for the connection of a room sensor (**TA₁**, see "*Connection Diagrams*"), which will make it possible to manage the heating service of the direct boiler circuit (**BC**) depending on the inside temperature of the house. For correct connection and configuration, carefully read the instructions in the "*Installing a room sensor or thermostat*" section..

The installation of a room sensor will optimise the operation of the heating installation, adapting the operation of the boiler to the needs of the home and improving comfort levels. The electronic control will modulate the boiler temperature setpoints according to the ambient conditions read by the sensor, optimising fuel savings and increasing the efficiency of the installation.

In turn, when there is a room sensor connected, the boiler's digital display will allow the programming of the operating hours of the corresponding circuit (see "*Configuration Menu*"), so the heating system can be adapted to the hours of use of the installation.

18 MULTI-FUNCTIONAL RELAY (P.20)

Bioclass iC DX is equipped with an auxiliary relay output that may be used to select a series of additional functions that increase the boiler performance, features and comfort of the installation.

Several operating modes may be set at **P.20** parameter of the "Technical Menu" to define the "multi-functional relay" function. The default value of this parameter is 0 (disabled). The following sections describe the functions that could be set.

18.1 Boiler alarms external signal (P.20 = 1)

When this function is selected (**P.20 = 1**) if the boiler shows an error or an operating alarm code the multi-functional relay output will be activated, supplying voltage (230 V~) between terminals no. **4**: "NO" and **N** of the terminal strip **J3**, where any external alarm signalling device may be connected to warn of boiler malfunctioning.

When the boiler lockage is reset, the multi-functional relay output will supply voltage again (230 V~) between terminals no. **3**: "NC" and **N** of the terminal strip **J3**.

18.2 DHW re-circulation function (P.20 = 2)

The DHW recirculation function (**P.20 = 2**) will keep the whole DHW installation hot during the operating periods programmed in the boiler, so when any hot water tap is turned on the hot water will be supplied instantly, increasing the comfort of the DHW installation.

A DHW re-circulation pump will be required to install in the installation. This pump has to be connected in the multi-functional relay output, between the terminals No **4** (**NO**) and **N** of the terminal strip **J3** (see "Connections diagram"). The hydraulic installation and electrical connection of re-circulation system must be made by qualified personnel.

During the operating periods programmed in the boiler, the multi-functional relay output will be activated, supplying voltage (230 V~) between terminals No **4** ("NO") and **N** of the terminal strip **J3**, where the recirculation pump must be connected. During the switched off periods programmed the multi-functional relay output will be deactivated, supplying voltage (230 V~) between terminals No **3** ("NC") and **N** of the terminal strip **J3** and the re-circulation pump will be stop.

18.3 Automatic water filling function (P.20 = 3)

Bioclass iC DX boiler may be connected to an automatic water filling system which can be activated or deactivated by **P.20** parameter.

It will be required to install a motorised valve to filling the water between the distribution water and the primary circuit of the boiler. This valve has to be connected in the multi-functional relay output between the terminals No **4** (**NO**) and **N** of the terminal strip **J3** (see "Connections diagram"). The hydraulic installation and electrical connection of the automatic water filling system must be made by qualified personnel.

If the function is enabled (**P.20 = 3**) the electronic controller of the boiler will active the multi-functional relay output supplying voltage (230 V~) between the terminals No **4** (**NO**) and **N** of the terminal strip **J3** (see "Connections diagram") that activates the connected filling valve to refill the primary circuit up to the pressure set at **P.21** parameter. If the boiler pressure drops below the minimum pressure set at **P.19** parameter the boiler will automatically fill up again until the filling pressure value is reached.

19 CLEANING THE ASH DRAWER

Bioclass iC DX boiler is equipped with an ash drawer, where the solid residues from the burnt fuel are collected on cleaning procedures of the burner and heat exchanger. This drawer must be regularly cleaned to prevent ash from accumulating and obstructing heat exchanger, what would cause the boiler to block out. It is recommended to check regularly the drawer and remove the ash that is accumulated.

The electronic control of the boiler has an automatic warning and monitoring function for the ashtray fill level. To activate it, see the "Ashtray emptying warning" section of the "Configuration" menu. When this function detects that the ashtray is full, it will emit a warning by activating the E-43 alarm, and the ash should be emptied. Once it has been emptied, **the ash level must be restored to 0** (see "Ashtray status"), so that the function can start again..

DOMUSA TEKNIK supplies an optional ash compacting device for to be installed within the boiler, so that the ash does not need to be removed so frequently.

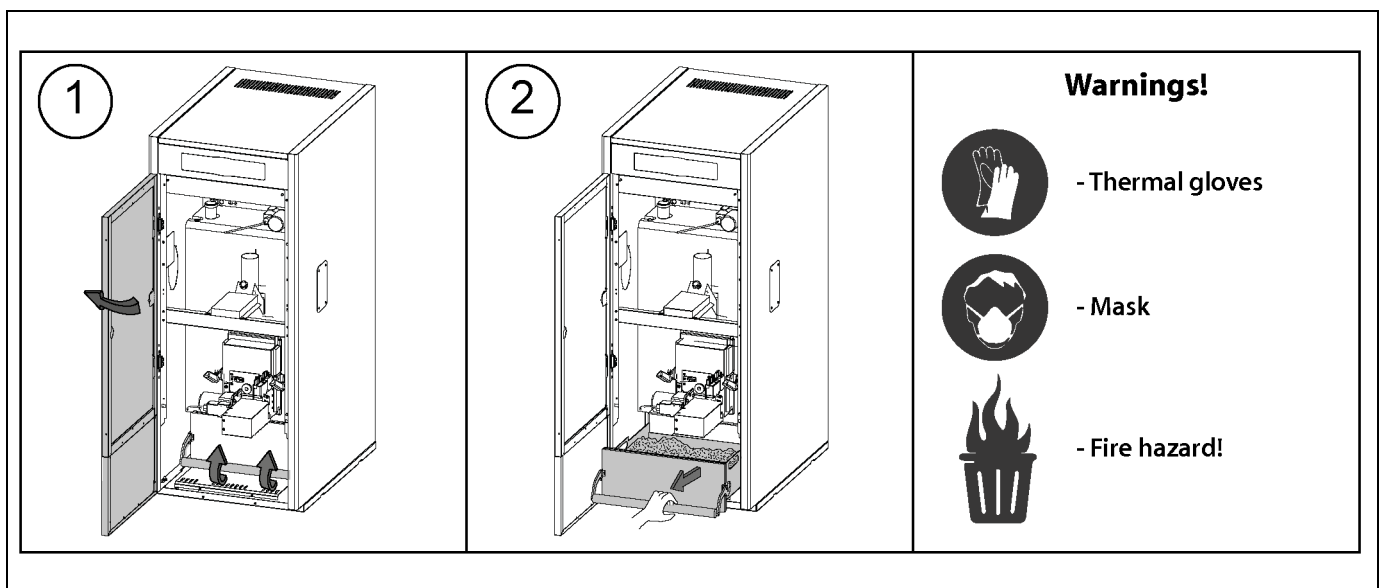

The user should regularly ensure that the ashtray is properly emptied, and check the boiler screen for its filling level.

REMINDER

A no regular emptying of the ashtray can result in premature fouling of the boiler and a fire.

To avoid failures or malfunctions, make sure that the ashtray is closed properly by pressing down tightly on the closing bar.

If the ashtray is not properly closed, an error code **E06**, **E13** or **E15** will appear on the screen, blocking the operation of the boiler.

IMPORTANT: Once the ashtray has been emptied, if the "Ashtray emptying warning" function is activated, the ash level must be reset to 0.

19.1 Safety warnings:

For **safe handling** of the ash drawer, you should take the necessary safety precautions and wear suitable clothing to protect against possible injury. The following advice should be particularly taken into account:

- **Switch off the boiler** before taking out the ash drawer. It is recommended to take out the ash drawer when no flame is detected in the burner.
- It is recommended to wear insulating **thermal gloves** to protect your hands from any burns from hot parts of the drawer.
- It is recommended you wear a protective **mask** to avoid breathing in any ash particles, particularly in the case of people with allergies or any type of respiratory problems, who should always wear a mask when carrying out ash removal.
- As the ash to be removed from the drawer may be burning or glowing, special precautions should be taken regarding to the type of container it is emptied into. A **metal** container is recommended, if not **the ash should be totally put out** using water or another extinguishing agent.

DOMUSA TEKNIK shall not be liable for any damage caused to people, animals or property as a result of incorrect handling of the ash drawer or the ash itself.

IMPORTANT: **The ash drawer must only be cleaned when the boiler is switched off or on pause.**

20 SAFETY LOCK-OUTS

The boiler's electronic controller may activate the following safety lock-outs to stop the boiler functioning in order to prevent serious damages. When any of these lock-outs occur, the boiler will switch off and an alarm code will be displayed on boiler's screen.

IMPORTANT: If any of the safety lock-outs described below should occur repeatedly, switch off the boiler and put in contact with the nearest official Technical Assistance Service.

20.1 Water overheat safety lock-out (E-11)

When this lock-out occurs "**E-11**" alarm code (temperature alarm) will appear on the screen. The burner will switch off and stop heating the installation.

This lock-out occurs when the temperature of boiler's water exceeds 110 °C. To unlock it, wait until the temperature drops below 100 °C and press the button of the safety thermostat, located underside of the electrical case of the boiler, after having removed the button cover:

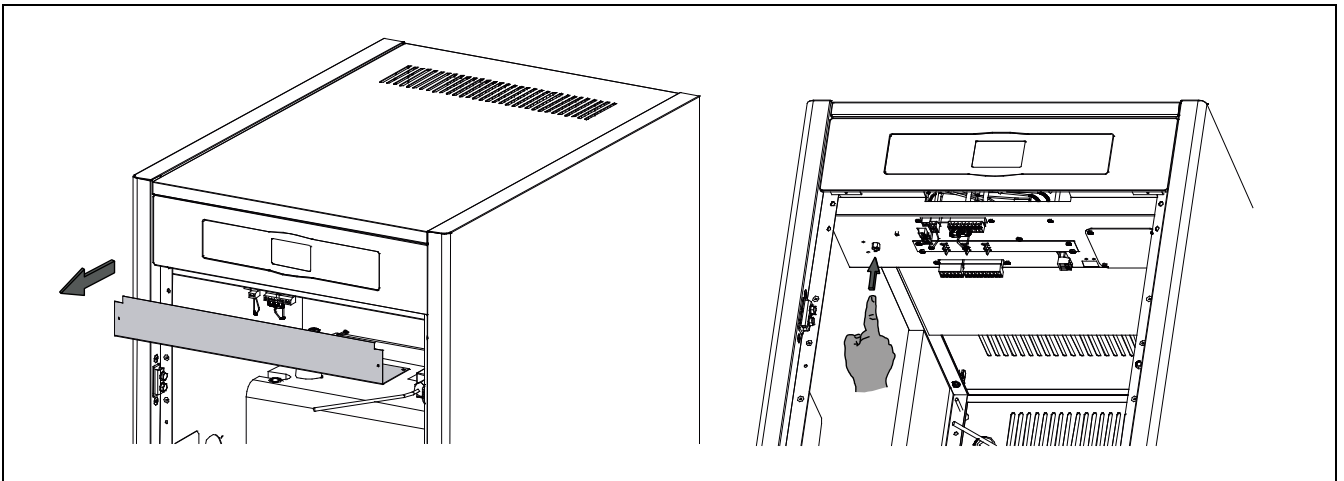

20.2 Fuel entrance tube overheat safety cut-out (E-05)

When this lock-out occurs "**E-05**" alarm code will appear on the screen. The burner will switch off and stop heating the installation.

This lock-out occurs when the temperature of the fuel entrance tube exceeds 80 °C. To unblock the boiler operation, once the tube temperature has dropped, press the reset button incorporated in the safety thermostat (*see figure*) and press the **RESET** symbol on the boiler control holder to restart operation.

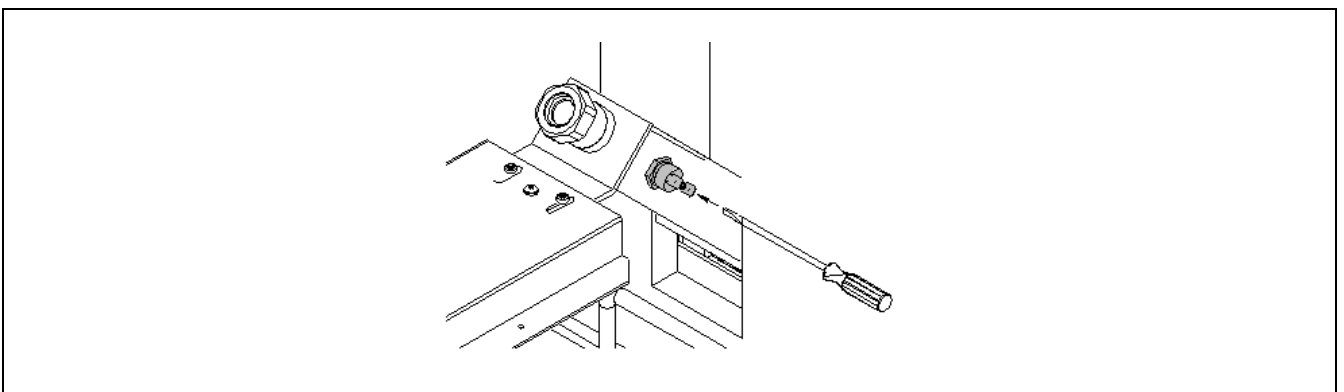

20.3 Low pressure lock-out

When this lock-out occurs, "E19" alarm code will appear on the digital display. The burner and the boiler's circulation pumps will switch off, cutting off the heating and water flow to the installation.

The blockage occurs when the boiler pressure drops below 0.5 bar, preventing it from working when the installation is drained of water, either due to a leak or due to maintenance operations. To unblock this alarm, the installation must be filled again (see "Filling the boiler"), until a pressure between 1 and 1.5 bar is displayed in the "water pressure" parameter of the "User Menu".

21 SHUTTING DOWN THE BOILER

Press  during 1 second to shut down the boiler. When the boiler is shut down the heating and DHW services are switched off but anti-frost and pumps anti-lock functions continue activated whereas the boiler is kept connected to the power supply and fuel installation.

Unplug the boiler from the power supply and cut out the fuel supply to shut down the boiler completely.

22 EMPTYING THE BOILER

Use the drain cock located on the bottom of the backside of the boiler to empty it of water. Before opening it, connect a flexible pipe leaded to a sewer. After finishing the procedure, close the cock and remove de flexible pipe.

23 BOILER MAINTENANCE

Various maintenance operations should be carried out at different intervals of time to keep the boiler in perfect working order. The yearly maintenance operations should be carried out by personnel authorised by **DOMUSA TEKNIK**.

23.1 Frequency of maintenance of the boiler and chimney

The most important aspects to be checked are as follows:

Nº	Operation	Frequency
1.	Check the fuel storage.	weekly
2.	Clean the ash in the ash drawer.	as required
3.	Check the boiler visually.	weekly
4.	Check if the feed auger is correctly calibrated.	as required
5.	Check and clean the boiler fume circuit.	yearly
6.	Check and clean the chimney. The chimney must be free of any obstacles and have no leaks.	yearly
7.	Clean the burner.	yearly
8.	Check the expansion vessel. It must be full, according to its data plate.	yearly
9.	Check the seal between the burner and the boiler.	yearly
10.	Check if the hydraulic circuits are correctly sealed.	yearly
11.	Check the water pressure of the boiler. When the installation is cold , it should be between 1 and 1.5 bar.	yearly



NOTE: Depending on the fuel type and weather conditions, it may be necessary to clean the combustion chamber of the burner at a bigger frequency.

23.2 Burner cleaning procedure

The **Bioclass iC DX** boiler has a burner (combustion chamber) where the combustion of the wood pellets takes place.

This burner must be cleaned regularly to avoid premature fouling due to the accumulation of slag (solid combustion residues) adhering to the burner walls.

Warning:

- To be carried out only when the boiler is off and cold
- Thermal gloves 
- Mask 
- Fire hazard 

The following procedure is recommended for a correct cleaning of the burner:

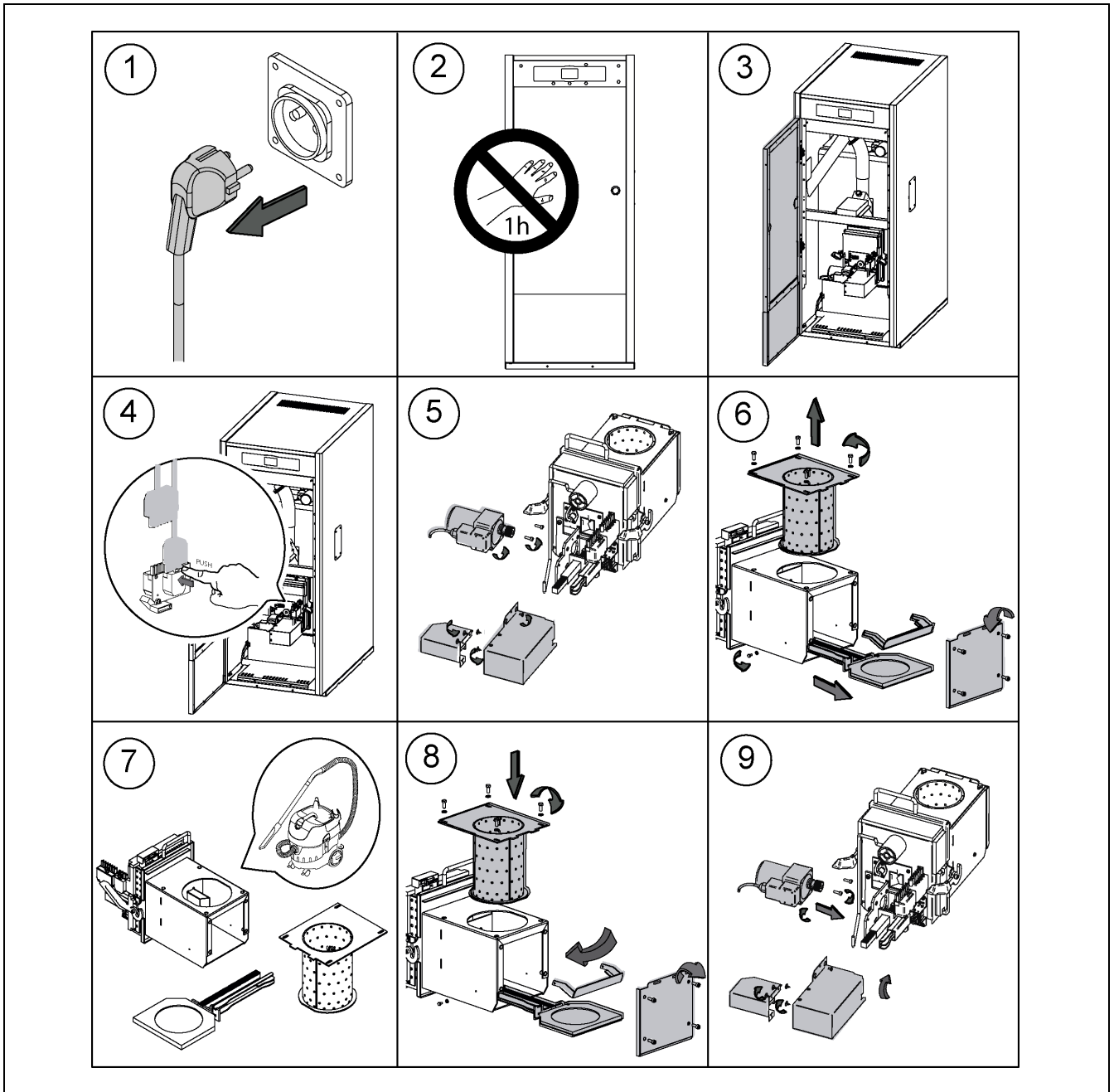

Depending on the quantity of wood pellets burned or its quality, the user must clean the walls of the burner using a suitable brush, in order to avoid excessive ash formation.

A regular check of the amount of fuel should be carried out in the hopper, as a lack of fuel can generate an error code **E06**.

Dust can also accumulate at the bottom of the hopper, depending on the quality and humidity of the wood pellets. If there is a large quantity of wood pellet dust in the hopper, **DOMUSA TEKNIK**-s authorised technical assistance service must be contacted for maintenance.

23.3 Heat exchanger cleaning procedure

The following procedure is recommended for correctly cleaning the heat exchanger:

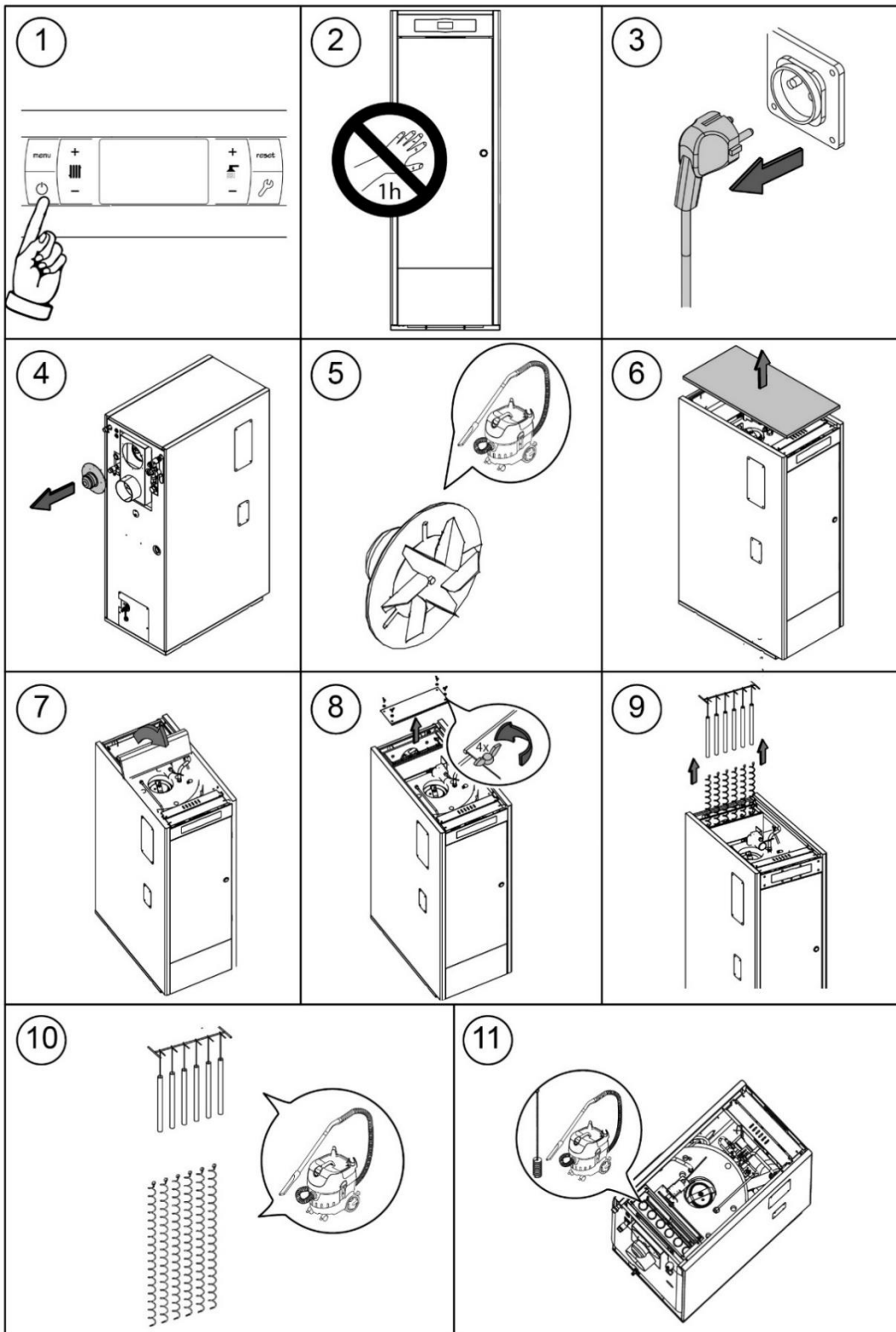

23.4 Draining the condensate water

The draining device to take out the condensate water from the chimney should not be altered in any way and it must be kept free of obstructions.

23.5 Boiler water characteristics

In areas with water hardness of over 25-30 °fH, treated water must be used in the heating installation to avoid any scale deposits on the boiler. It should be noted that even a few millimetres of scale will greatly reduce the boiler's heat conductivity, causing a major drop in performance.

Treated water must be used in the heating circuit in the following cases:

- Very large circuits (containing a large amount of water).
- Frequent filling of the installation.

If it is necessary to drain partially or totally the water of the installation very often, we recommend filling it with treated water.

23.6 DHW characteristics

DHW will need to comply with the characteristics defined in the legislation in force of the country where the boiler will be installed.

Moreover, it will need to be according to the Directive 98/83/CE relative to the quality of water destined for human consumption. Special attention will need to be pay in the following parameters:

- Maximum chlorides concentration: 250 mg/l.
- Maximum sulphates concentration: 250 mg/l.
- Sum of chlorides and sulphates concentration: 300 mg/l.
- Maximum conductivity: 800 µS/cm.

IMPORTANT NOTE

- Improper handling of the boiler can lead to serious or even fatal failures for the appliance.
- Therefore, it is strictly forbidden for the user of the boiler to enter the TECHNICAL parameters, which are values that can directly affect the correct operation and destruction of the appliance.
- Only an authorized **DOMUSA TEKNIK** technical service can access it.
- The user must ensure that the water pressure in the installation is correct, that is, a pressure of 1.5 bar.
- If the pressure is less than 0.5 bar, an E19 error code will appear on the display and an E28 code will appear if the pressure is greater than 2.5 bar. The standard vents where the boiler is located (boiler room) must in no case be obstructed or partially obstructed. The maintenance of the boiler will be carried out in accordance with what is specified in this brochure. The appliance should be visually inspected regularly for any leaks or malfunctions.
- It is MANDATORY that maintenance operations be carried out by an approved professional from the **DOMUSA TEKNIK** network, at least once a year on the boiler and twice a year on the flue, according to the standards in force.

24 DIAGRAMS AND MEASUREMENTS

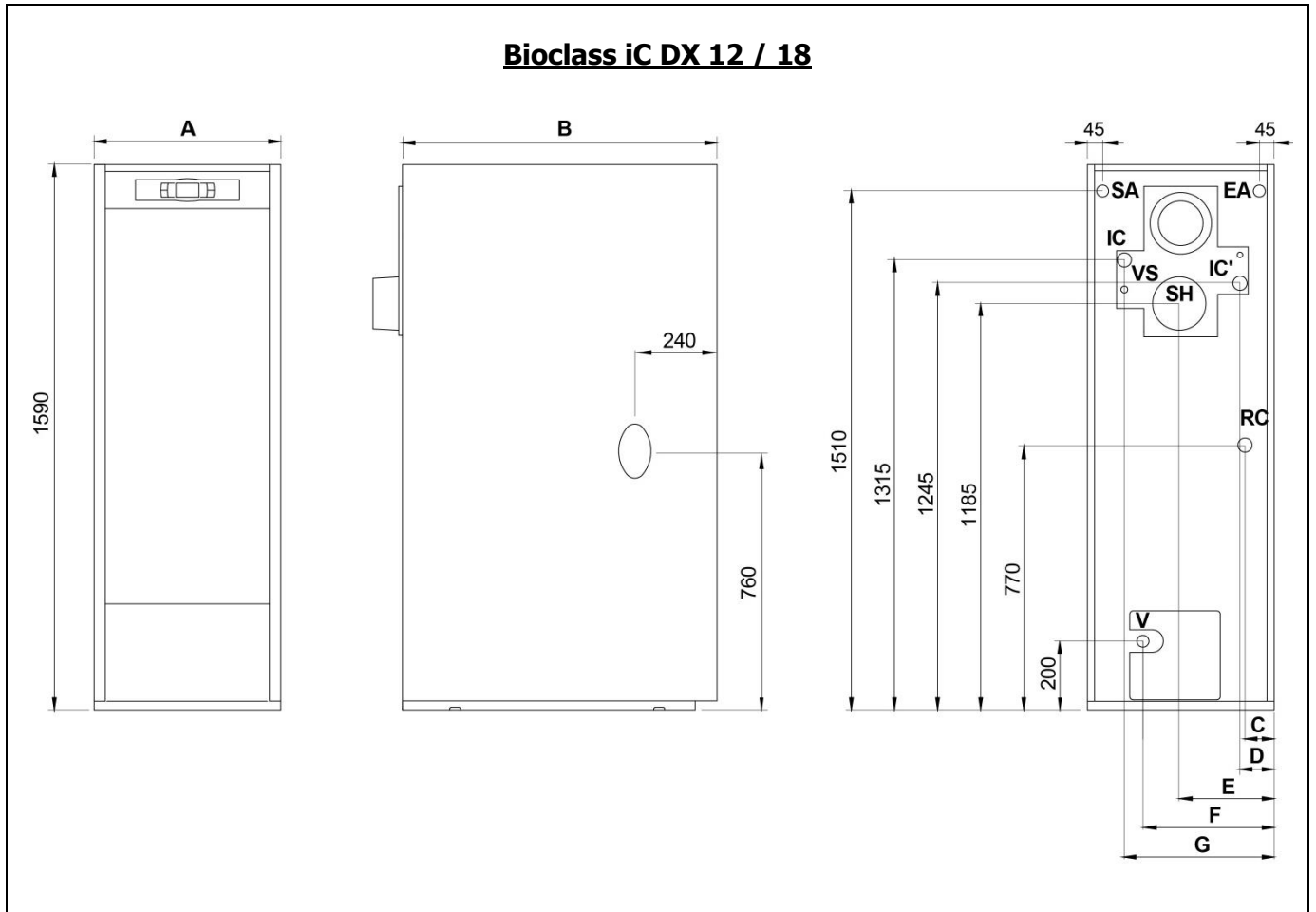

- IC:** Heating flow.
- RC:** Heating return.
- SA:** Sanitary water outlet.
- RC:** Sanitary water return.
- IC':** Heating Flow optional.
- SH:** Fume outlet.
- V:** Drainage cock.
- VS:** Pressure e relief valve, 1/2" F.

		Dimensions (mm)							
	IC/RC	A	B	C	D	E	F	G	SH
Bioclass iC DX 18	1"H	545	920	85	100	270	350	445	Ø100
Bioclass iC DX 25		670	1020	95	100	335	460	570	Ø100

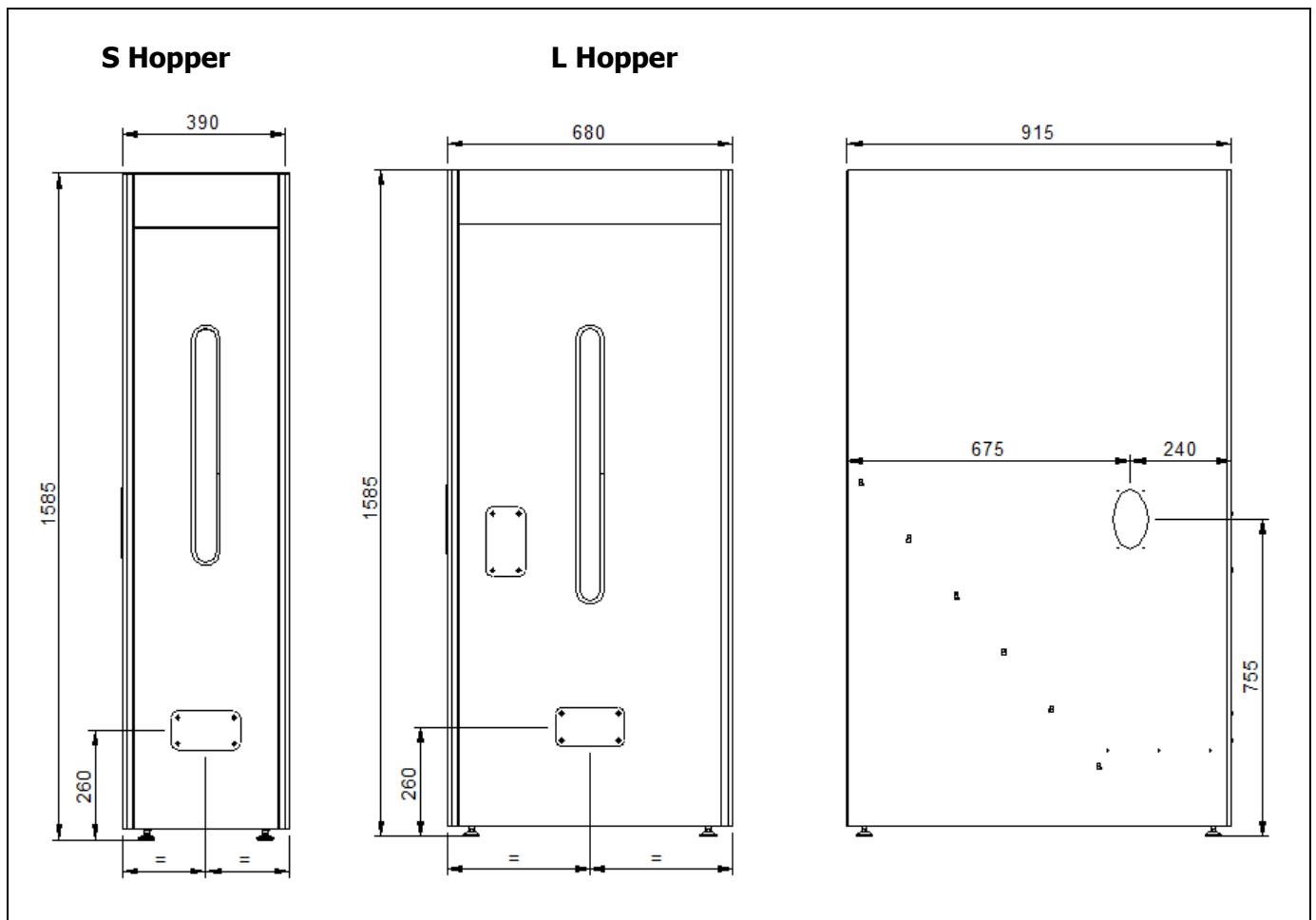

	S Hopper		L Hopper	
	P _c	Size	P _c	Size
Bioclass iC DX 18	67	370 Litres	101	560 Litres
Bioclass iC DX 25	48		73	

P_c: Combustion period in hours at Q_N.

25 CONNECTIONS DIAGRAM

25.1 Boiler

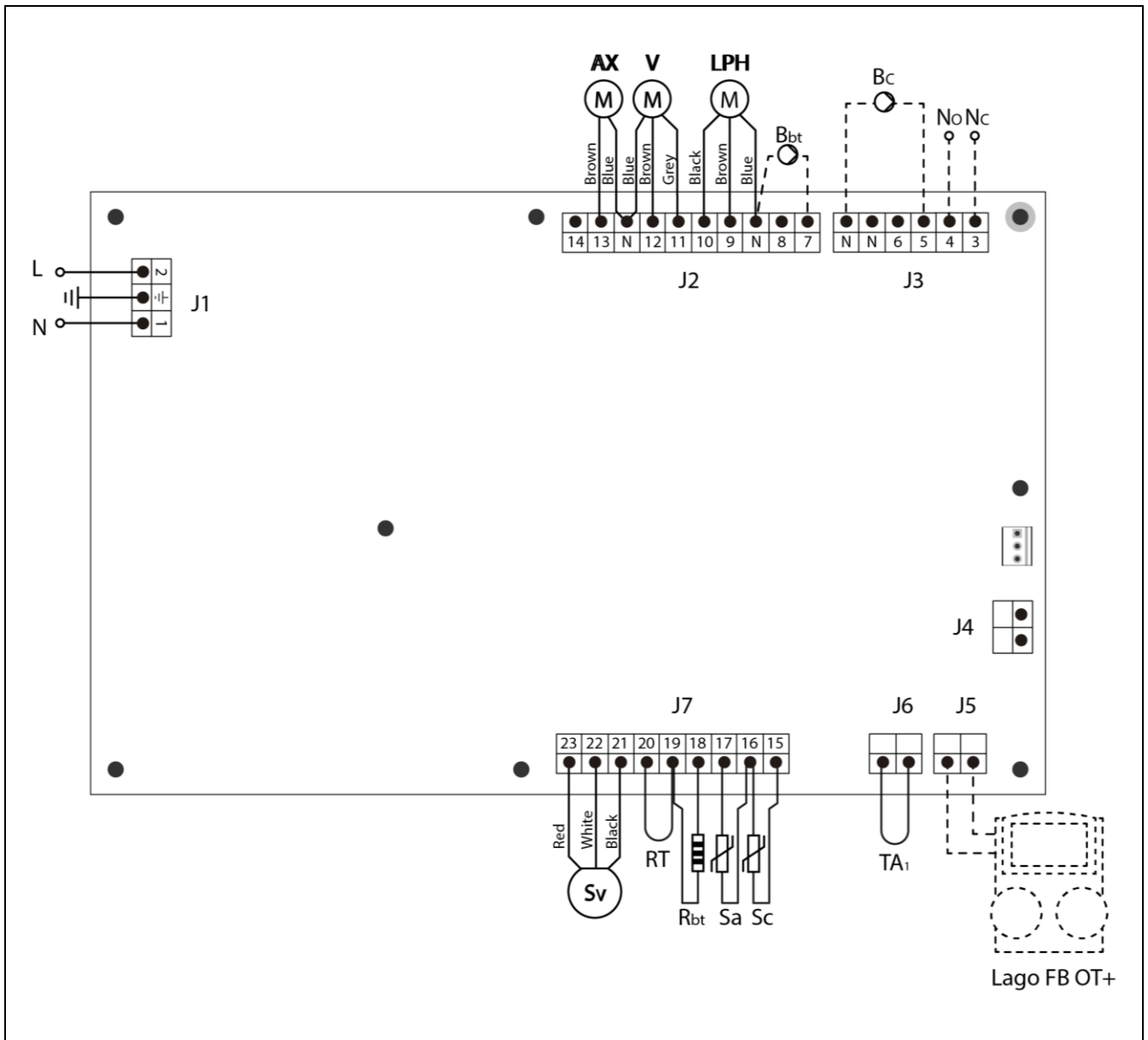

L: Phase.

N: Neutral.

AX: Feed auger.

V: Fan.

LPH: Heat exchanger cleaning device.

Bbt: BT buffer tank charging pump.

BC: Boiler pump.

NO: Multi-functional relay.

NC: Multi function relay.

TA₁: Room Temperature Device.

Sc: Boiler temperature sensor.

Sa: DHW tank option resistance.

Rbt/Sbt: Resistance for BT tank Option.

RT: Remote relay.

Sv: Fan speed sensor.

J1: Power supply connector.

J2: Component connector.

J3: Component connector.

J4: Communication connector.

J5: **LAGO FB OT+** remote control connector.

J6: Room Temperature Device connector.

J7: Sensors connector.

26 ELECTRICAL DIAGRAM

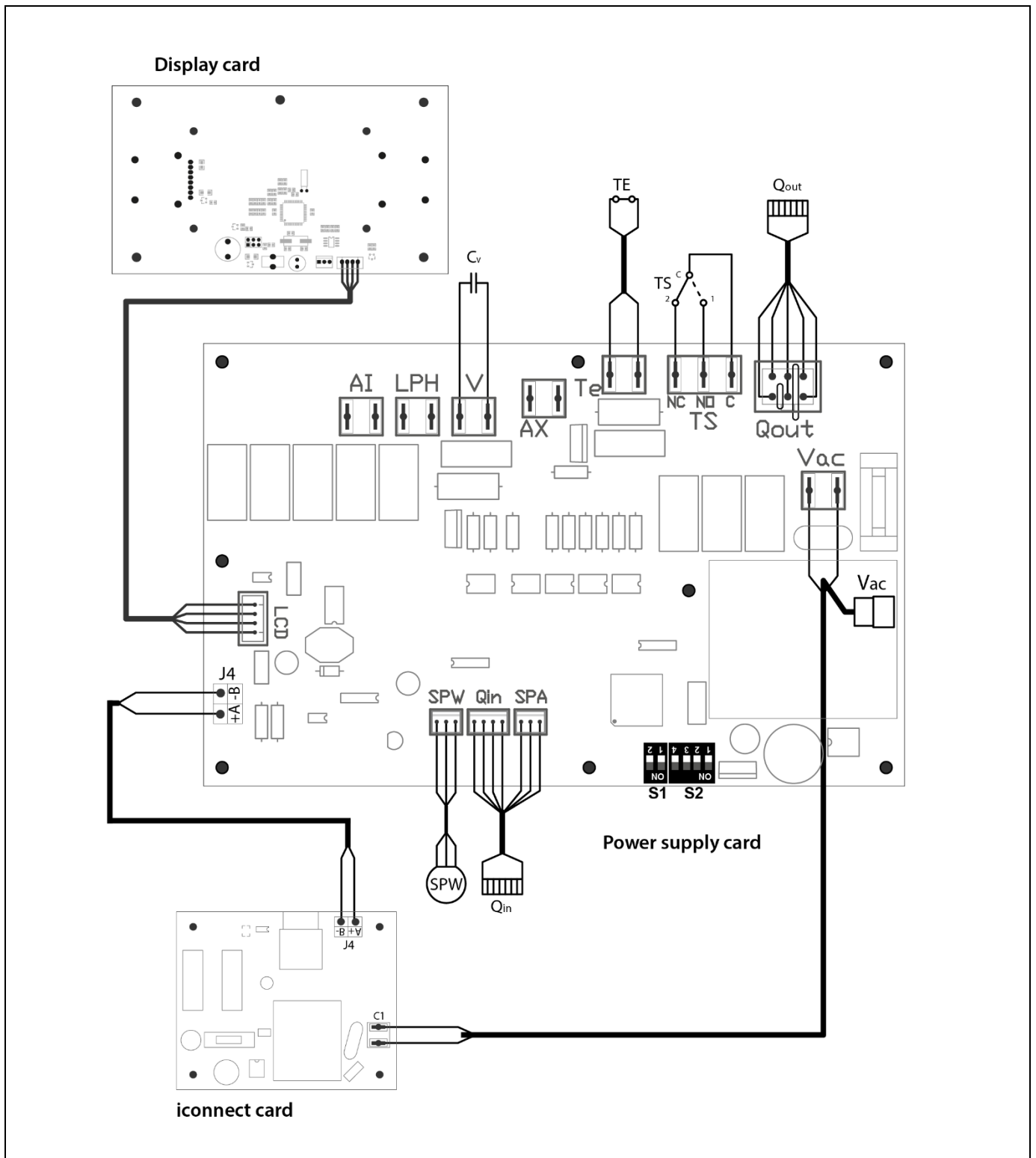

- TS:** Safety thermostat.
- TE:** Fuel entrance safety thermostat.
- Cv:** Fan capacitor.
- SPW:** Water pressure sensor.
- SPA:** Air pressure sensor.
- Qout:** Burner outputs connector
- Qin:** Burner inputs connector.
- LCD:** Display communication connector.
- J4:** Communication connector.
- Vac:** iConnect card power supply
- C1:** iConnect card power supply
- S1, S2:** Boiler model DIP-switch.

27 TECHNICAL DATA

MODEL		BioClass iC DX 18	BioClass iC DX 25
Rated heat output (P _n)	kW	17,6	24,8
Efficiency at maximum heat output	% (NCV)	94,1	92,2
Minimum heat output (P _p)	kW	5,4	6,9
Efficiency at minimum heat output	% (NCV)	93,8	90,4
CO at maximum heat output (10% O ₂)	mg/m ³	18	32
OGC (organic gaseous substances) at maximum heat output (10% O ₂)	mg/m ³	3,9	0
Particles content at maximum heat output (10% O ₂)	mg/m ³	6	13
CO at minimum heat output (10% O ₂)	mg/m ³	37	41
OGC (organic gaseous substances) at minimum heat output (10% O ₂)	mg/m ³	4,4	5
Partial load dust content (10% O ₂)	mg/m ³	4	6
Boiler class (according to EN 303-5)	-	Class 5	
Maximum operating pressure	bar	3	
Maximum operating temperature	°C	80	
Maximum safety temperature	°C	110	
Water volume	litros	178	224
Minimum flue draught	mbar	0,05	
Maximum flue draught	mbar	0,20	
Flue gas mass flow rate at nominal/partial load	Kg/s	0,013/0,005	0,018/0,006
Flue gas temperature at nominal/partial load	°C	140/90	
Electrical supply	-	230 V~, 50 Hz, 2,50 A	
Boiler chimney diameter	mm	100	100
Maximum water content of the fuel	%	7	
Minimum return temperature	°C	25 °C	
Water pressure drop (dT = 20 K)	mbar	63	130
Noise level (according to 15036-1)	dB	56	56
Weight (net)	Kg	290	370

MODELO		BioClass iC DX 18	BioClass iC DX 25	
Rated heat output (P_n)	kW	17,6	24,8	
Efficiency at maximum heat output (η_n)	% (PCS)	87	85	
Minimum heat output (P_p)	kW	5,4	6,9	
Efficiency at minimum heat output (η_p)	% (PCS)	87	84	
Feeding mode	-	Automatic (*)		
Condensing boiler	-	No		
Combined boiler	-	Si		
Cogeneration boiler	-	No		
Combustible	-	Wood Pellet Ø6 - 8 mm. Maximum length 35 mm.		
Seasonal yield (η_s)	%	84	80	
Seasonal heating emissions	Part.	mg/m ³	4,3	7
	OGC	mg/m ³	4,3	4
	CO	mg/m ³	34,15	40
	NO _x	mg/m ³	143	159
Electricity consumption at nominal power ($e_{l_{max}}$)	kW	0,058	0,053	
Electricity consumption at 30% nominal power ($e_{l_{min}}$)	kW	0,028	0,034	
Electricity consumption in standby mode (P_{SB})	kW	0,007	0,007	
Energy Efficiency Index - EEI	-	122	117	

*** It is recommended to use the boiler with a hot water storage tank of a minimum volume of 20 x P_n with P_n indicated in kW.**

28 ALARM CODES

Bioclass iC DX boiler is equipped with an electronic controller that performs continuous self-testing to detect any boiler malfunctioning. When it detects a functioning error, this is indicated by an alarm code on the display. The table below shows the list of the alarm codes:

Code	Alarm	Description
E-01	Boiler temperature sensor open circuit, S_c .	The boiler sensor is damaged or disconnected. Contact your nearest official technical assistance service to have it replaced.
E-02	Boiler temperature sensor short-circuited, S_c .	
E-03	DHW temperature sensor open circuit, S_a .	The DHW sensor is damaged or disconnected. Contact your nearest official technical assistance service to have it replaced.
E-04	DHW temperature sensor short-circuited, S_a .	
E-05	Overheating in fuel entrance tube, Te .	The security thermostat of fuel entrance tube has exceeded the safety temperature of 80 °C. The boiler will lock out. To unlock the boiler wait the temperature drops, press the button on the safety thermostat and restore by pressing RESET button. If this alarm occurs repeatedly contact the nearest official technical assistance service.
E-06	Ignition failure.	Check the fuel content in the hopper or calibrate the feed auger. If this alarm occurs repeatedly contact the nearest official technical assistance service.
E-07	Burner ash cleaning system start step error.	These alarms occur when a bad running of the burner ash cleaning system is detected. If this alarm occurs repeatedly contact the nearest official technical assistance service.
E-08	Burner ash cleaning system final step error.	
E-09	Burner ash cleaning system switch error, FC_p .	
E-10	Boiler water overheating.	The water in the boiler has exceeded the safety temperature of 100 °C. The boiler will lock out. The boiler will be unlocked automatically when the boiler temperature drops below 90 °C. If this alarm occurs repeatedly contact the nearest official technical assistance service.
E-11	Safety thermostat, Ts .	The water in the boiler has exceeded the safety temperature of 110 °C. The boiler will cut out. To unlock it, wait until the boiler drops below 100 °C and press the button on the safety thermostat. If this alarm occurs repeatedly contact the nearest official technical assistance service.
E-12	Burner switch, FC_q .	Check if the burner is correctly fitted to the boiler. If this alarm occurs repeatedly contact the nearest official technical assistance service.
E-13	Insufficient air depression.	Check the correct running and connection of the air pressure sensor and that the burner and ashtray are correctly fitted to the boiler. If this alarm occurs repeatedly contact the nearest official technical assistance service.
E-14	Air depression fall down.	
E-15	Insufficient air depression during ignition pre-purge step.	
E-18	Water pressure sensor fault.	The water pressure sensor is damaged or disconnected. Contact your nearest official technical assistance service to have it replaced.
E-19	Low water pressure.	The pressure of water in the installation drops below the minimum pressure set at P.19 parameter of the " <i>Technical Menu</i> " (by default 0,5 bar). The boiler will lock out. To unlock it, fill the installation again up to 1 - 1.5 bar. This alarm occurs when the water is drained from the installation, due to either leakage or maintenance operations. If this alarm occurs repeatedly contact the nearest official technical assistance service.

Code	Alarm	Description
E-20	Safety valve fault.	When the installation pressure exceeds 3.5 bar, this alarm is displayed on the screen. The safety valve is damaged or it doesn't work properly. The boiler will lock out. The boiler will be unlocked, when the pressure drops below 2.5 bar again. Drain the installation up to 1 - 1.5 bar. Contact your nearest official technical assistance service to have it replaced.
E-21	Air pressure sensor fault.	The air pressure sensor is damaged or disconnected. Contact your nearest official technical assistance service to have it replaced.
E-22	Excessive air depression in the combustion chamber.	The air depression measured in the combustion chamber exceeds the limits of the air pressure sensor. The burner will be locked until the depression is correct again. If this alarm occurs repeatedly contact the nearest official technical assistance service.
E-23	Excessive air overpressure in the combustion chamber.	The air overpressure measured in the combustion chamber exceeds the limits of the air pressure sensor. The burner will be locked until the depression is correct again. If this alarm occurs repeatedly contact the nearest official technical assistance service.
E-25	Wrong calibration data.	The calibration data is wrong or it is set at OFF value. If this alarm occurs repeatedly contact the nearest official technical assistance service.
E-26	Communication error with CVS Suction System .	Communication failure between boiler and CVS Suction System . The kit will lock out. When the communication is restored CVS Suction System will be unlocked. If this alarm occurs repeatedly contact the nearest official technical assistance service.
E-27	CVS Suction System blockage.	If the level sensor continues to detect no fuel after 8 consecutive cycles, CVS Suction System will lock out. To unlock it press RESET button. If this alarm occurs repeatedly contact the nearest official technical assistance service.
E-28	Overpressure of water.	When the boiler water pressure exceeds 2.5 bar, this alarm is displayed on the screen to warn of an excess of pressure in the installation. To restore the normal functioning of the boiler it is recommended to drain the installation again up to 1 - 1.5 bar. If this alarm occurs repeatedly contact the nearest official technical assistance service.
E-29	Fuel level sensor error.	Fuel level sensor is damaged or disconnected. Contact your nearest official technical assistance service to have it replaced.
E-30	Underfloor temperature sensor open circuit, Sr1 .	Underfloor temperature sensor is damaged or disconnected. Contact your nearest official technical assistance service to have it replaced.
E-31	Underfloor temperature sensor short-circuited, Sr1 .	
E-32	Underfloor temperature sensor open circuit, Sr2 .	Underfloor temperature sensor is damaged or disconnected. Contact your nearest official technical assistance service to have it replaced.
E-33	Underfloor temperature sensor short-circuited, Sr2 .	
E-34	Outdoor temperature sensor open circuit, Sext .	Outdoor temperature sensor is damaged or disconnected. Contact your nearest official technical assistance service to have it replaced.
E-35	Outdoor temperature sensor short-circuited, Sext .	

Code	Alarm	Description
E-36	DIP-switch wrongly changed.	DIP-switch selector of the boiler is changed when the boiler is connected to the main supply. The boiler will be locked out until unplug and plug the boiler again.
E-37	Communication error with BIO Hydraulic Kit .	Communication failure between boiler and the BIO Hydraulic Kit. If this alarm occurs repeatedly contact the nearest official technical assistance service.
E-38	Lasting insufficient air depression during ignition pre-purge step.	Check the air pressure sensor and that the burner and ashtray are correctly fitted to the boiler. If this alarm occurs repeatedly contact the nearest official technical assistance service.
E-39	Insufficient fan speed.	Fan malfunction. If this alarm occurs repeatedly contact the nearest official technical assistance service.
E-40	Fan speed fall down.	
E-41	Lasting fan speed fall down.	
E-42	Communication error with BIO Hydraulic Kit .	Communication failure between boiler and the BIO Hydraulic Kit . If this alarm occurs repeatedly contact the nearest official technical assistance service.
E-43	Ashtray full.	Warning that the ashtray is full. The boiler will continue operate normally. To restore warning, the ashtray must be emptied and it is necessary to set the "Emptying ashes" parameter to 0 of the "User menu" (See "Ashtray status").
E-44	Boiler Maintenance.	Notice for maintenance of the boiler. Contact your nearest official technical assistance service to perform periodic maintenance of the boiler.
E-45	BT tank temperature sensor open circuit, Sbt .	BT tank temperature sensor is damaged or disconnected. Contact your nearest official technical assistance service to have it replaced.
E-46	BT tank temperature sensor short-circuited, Sbt .	
E-47	Communication error with pellets level sensing unit.	Communication failure between boiler and the pellets sensing system board (PCB). If this alarm occurs repeatedly contact the nearest official technical assistance service.
E-48	Low fuel level in the hopper.	Warning that the hopper is going to run out of pellets (fuel reserve). The boiler will continue operate normally. Refill the hopper with pellets up to the sensor to restore the warning alarm.
E-49	Hopper is run out of fuel.	The hopper is completely empty of pellets. The boiler stops running to avoid emptying the auger. To restore boiler functioning refill the hopper with pellets up to the sensor and press RESET button.
E-50	CVS Suction System and pellets sensing units connected together.	CVS Suction System and pellets sensing units are connected together to boiler's main board. Contact your nearest official technical assistance service to disconnect one of the units.
E-57	Zone 1 TA ₁ room sensor open circuit.	The Zone 1 room temperature device is broken or disconnected. Please contact your nearest official Technical Assistance Service to have it replaced.
E-58	Zone 1 TA ₁ room temperature sensor short-circuited.	
E-59	Zone 2 TaM ₁ room sensor open circuit.	The Zone 2 room temperature device is broken or disconnected. Please contact your nearest official Technical Assistance Service to have it replaced.
E-60	Zone 2 TaM ₁ room temperature sensor short-circuited.	

Code	Alarm	Description
E-61	Zone 3 TaM ₂ room sensor open circuit.	The Zone 3 room temperature device is broken or disconnected. Please contact your nearest official Technical Assistance Service to have it replaced.
E-62	Zone 3 TaM ₂ room temperature sensor short-circuited.	
E-63	Insufficient maximum power.	Combustion circuit in poor conditions: chimney clogged or dirty, insufficient draft, clogged or dirty smoke passage, clogged air inlet duct... If this alarm occurs repeatedly, please contact the nearest official Technical Assistance Service.
E-64	Communication error with iConnect module.	Communication error between the boiler and the iConnect electronic card. If this alarm occurs repeatedly, please contact the nearest official Technical Assistance Service.
E-65	There is no serial number on the iConnect module.	The serial number of the boiler has not been registered on the iConnect electronic card. Please contact your nearest Official Technical Assistance Service to correctly register it.



DOMUSA

T E K N I K

POSTAL ADDRESS

Apartado 95
20730 AZPEITIA
Spain

HEADQUARTERS & FACTORY

Bº San Esteban s/n
20737 RÉGIL (Guipúzcoa)
Tel: (+34) 943 813 899



CDOC002496 23/12/21

www.domusateknik.com

DOMUSA TEKNIK reserves the right to make modifications of any kind to its product characteristics without prior notice.